

Warranty Repair Guidelines

TCWY1250 EN-US

August 2017



Powering Business Worldwide

BACKED BY

Roadranger

SUPPORT

Table of Contents

Mechanical Transmission

(Pre-Authorization Warranty Repairs)

RWRG0004 - Clutch Housing Gasket Leak	1
RWRG0005 - External Heat Exchange (Cooler) Failure	3
RWRG0007 - Internal heat Exchange (Cooler) Failure	5
RWRG0031 - Splitter, Cylinder, Dry / Oil Ingestion on 13 - 18 Speeds	7
RWRG0032 - Output Looseness	9
RWRG0034 - Output Seal Leakage	11
RWRG0040 - Low Range Synchronizer Failure	13
RWRG0042 - Air Filter Regulator Failure	15
RWRG0043 - High Range Synchronizer Failure	17
RWRG0060 - Auxiliary Case to Main Case Gas-ket Leak	19

Mechanical Transmissions

RWRG0001 - Auxiliary Drive Gear Bearing Failure	21
RWRG0002 - Auxiliary Countershaft Bearing Failure	23
RWRG0003 - Auxiliary Drive Gear Bearing Failure	25
RWRG0006 - Air Module Failure	27
RWRG0012 - Range Yoke Snap Ring Failure	29
RWRG0016 - Front Countershaft Bearing Failure	31
RWRG0017 - Front Countershaft Bearing Failure	33
RWRG0018 - Front Section Countershaft Loose Gears	35
RWRG0020 - Lever Entrapment / Lever Escapes From Shift Blocks	37
RWRG0027 - Input Shaft Breakage	39
RWRG0033 - Output Bearing Failure	41
RWRG0037 - Towing Damage	43
RWRG0038 - Transmission Overheating	45

Clutch (Pre-Authorization Warranty Repairs)

RWRG0052 - Broken Spring Cover	47
RWRG0053 - Broken Damper Spring-7 Spring Damper	51

RWRG0054 - Broken Hub Rivets-7 Spring Damper	53
--	----

Clutch

RWRG0045 - Broken Cam Spring	55
RWRG0046 - Idle Rattle	57
RWRG0047 - Seized Solo Adjusting Cam	59
RWRG0049 - Broken Intermediate Plate Aluminum Ring	61

Automated Transmission (Pre-Authorization Warranty Repairs)

RWRG0051 - Splitter Complaint - Fault Code 42	63
RWRG0056 - Range Shift Complaints - Fault Code 41	65
RWRG0063 - Range Shift Complaint - Fault Code 43	67
RWRG0069 - Fault Code 64 on Generation 1 Electronic Clutch Actuator (ECA)	69
Fault Code 64 Troubleshooting and Repair Guidelines	72
RWRG0070 - X-Y Shifter Leaks	75
RWRG0071 - Transmission Electronic Control Unit Fault Code 11 FMI 12 Pre-Authorization	77
Fault Code 11 Troubleshooting	78
RWRG0072 - Fault Code 46 Pre-Authorization	79
Fault Code 46 Troubleshooting	82
RWRG0073 - Fault Code 51 Rail Position Sensor Pre-Authorization	83
Fault Code 51 Troubleshooting	86
RWRG0074 - Fault Code 52 Pre-Authorized Repair	91
Fault Code 52 Troubleshooting	94
RWRG0075 - Input Shaft Speed Sensor Pre-Authorization	99
Fault Code 56 Troubleshooting	102
RWRG0076 - Main Shaft Speed Sensor Pre-Authorization	105
Fault Code 57 Troubleshooting	108
RWRG0077 - Fault Code 61 Pre-Authorization	111
Fault Code 61 Troubleshooting	114

Table of Contents

RWRG0078 - Fault Code 63	
Pre-Authorization	117
Fault Code 63 Troubleshooting	120
RWRG0079 - Generation 1 Electronic Clutch Actuator (ECA) Only Pre-Authorized Fault Code 65 Repair Guideline	123
Fault Code 65 Troubleshooting	126
RWRG0080 - Fault Code 71	
Pre-Authorization	131
Fault Code 71 Troubleshooting	134
RWRG0081 - Fault Code 73	
Pre-Authorization	137
Fault Code 73 Troubleshooting	140
 Automated Transmission (Pre-Authorization Warranty Repairs)	
RWRG0067 - Shift Complaints, No Transmission Fault Codes	143

Pre-Authorized Warranty Repair Guideline RWRG0004

RWRG0004 - Clutch Housing Gasket Leak

Symptom(s)

- Oil leakage

NOTE ON NEW VEHICLES: A new transmission may have some residual assembly oil sprayed inside the clutch housing. This residual oil may be mistaken for a leak. When a new unit has a suspected oil leak inside the clutch housing, clean the area thoroughly, verify lube level and run the vehicle to confirm a leak prior to disassembly.

Cause

Oil Leaking to the Outside of the Clutch Housing

Possible Causes:

- Pump plug or pump plug o-ring is leaking (RT Models)
- Clutch housing attaching studs or bolts loose in case
- Clutch housing gasket mis-installed
- Casting or machining flaw in the clutch housing or case
- Wrong clutch housing gasket installed
- Input bearing cover gasket is torn or missing
- Pump bolts loose and leaking
- Forced Lube Tube interference
- Lube level is overfull

Oil Leaking to the Outside of the Clutch Housing

Possible Causes:

- Attaching studs or bolts loose in the case
- Clutch housing gasket torn, folded or missing
- Wrong clutch housing gasket installed
- Trans case or clutch housing surfaces mis-machined
- Pump dowel pin protruding from the main case front wall
- Forced lube tube interference

Repair Guideline

Remove the transmission and inspect for possible causes listed above. If the case or clutch housing surfaces are damaged their replacement would not constitute a pre-authorized repair.

RT Models:

If oil is puddled behind the gasket at the oil pump plug area, the pump plug o-ring may be the root cause and the O-ring should be replaced. Lubricate the o-ring and use care reinstalling the plug into the case bore by hand only. Do not strike with a hammer or driver.

12 fasteners (instead of 10) have been in use on RT models since July 2004. More information on the 12 fastener system can be found in service bulletin TMIB0145 available on Roadranger.com.

FR Models:

In May 2010 grade 9.5 fasteners with dual conical washers and increased torque specifications were added to improve clamp load. The latest clutch housing gasket and fasteners can be purchased as a kit and should be used when appropriate. (See warranty parts below).

Warranty Parts

- RT models, pump plug O-ring
- Clutch housing gasket
- Front bearing cover gasket
- Shift tower gasket
- Top off Lube (\$30 max)

For part numbers refer to the Eaton InfoRanger site, www.inforanger.roadranger.com, or a current IPL.

Warranty Labor

Transmission R&R per OEM published SRT (Additional accessories/equipment required to remove transmission to be submitted per OEM published SRTs)

Bench time for Clutch Housing R&R per OEM SRT.

Warranty Coding

Part: Gasket (or causal part)

Complaint: Oil leak

Failure: Leak

Pre-Authorized Warranty Repair Guideline RWRG0004

Warranty Claim Filing

Reference warranty coverage. File pre-authorized warranty claim through appropriate OEM or through Direct Pay. Reference guideline number RWRG0004 in warranty claim text.

Note: Repairs that exceed parts and labor parameters cannot be pre-authorized.

Filing through Direct Pay

Click here for Direct Pay submission guidelines and claim forms:



Parts Disposition

Parts can be scrapped.

Warranty Disclaimer

If the failure is not the result of accident, damage, negligence, abuse or misuse, improper installation or maintenance or any other conditions described in the Limits and Exclusions section of Warranty Manual TCWY0600, available on Roadranger.com, then Roadranger will treat the condition as covered under its warranty. However, this conclusion does not necessarily mean that a defect in fact exists. In all cases, Roadranger shall make the final determination and interpretation as to the warrantability of the Product.

IMPORTANT: Warranty will not pay damage caused from a low lube condition or consequential damage caused by the leak left unrepaired.

Pre-Authorized Warranty Repair Guideline RWRG0005

RWRG0005 - External Heat Exchange (Cooler) Failure

Symptom(s)

- Unexplained coolant loss
- Oil mixture found in the radiator
- Engine coolant in the transmission oil
- Oil pushing out shift tower, rear seal or through input shaft cover hole
- External oil leak from cooler

Warranty Coverage

Eaton external heat exchangers (coolers) and lines are covered for a maximum of 3 years/300,000 miles, or dependent on transmission vocation.

No extended coverage is available for oil coolers.

Cause

Internal leakage:

Earlier coolers can fail internally causing the engine coolant and transmission oil to mix.

The cooler was improved with “floating bundle” technology.

The latest coolers have the square flange on both ends.

See Information Bulletin TAIB0859, available on Roadranger.com, for more details. This bulletin also includes a cross reference to the new heat exchanger (cooler) part numbers. The Eaton part number is stamped on the heat exchanger (cooler).

External leakage:

Occasionally coolers develop external oil leaks.

Check for damage or issues with the heat exchanger (cooler) line fittings, cooler bracket attachment areas or porosity in the housing.

Check oil cooler lines for leaks.

Note: Eaton heat exchanger (cooler) lines were improved in 2001 to make them more robust against heat and oil additives. Be aware that prior to that, lines could become brittle and when disturbed may crack internally causing subsequent leaks.

Repair Guideline

Always pull the PTO cover or PTO unit to inspect the internal condition of the transmission.

Damage is rarely found because during operation the oil/coolant mixture emulsifies and does offer some cooling/lubrication. Often times the transmission is clean and only the oil needs to be replaced.

If the transmission is contaminated it should be flushed with DEXRON ATF. See transmission flush procedure in service bulletin TMIB0124, available on Roadranger.com.

If the front box gears are scored or there is apparent transmission damage pull transmission and perform repairs.

Replace the heat exchanger (cooler) with updated part.

Warranty Parts

- Heat exchanger (cooler)
- New lube
- Coolant (if required)
- ATF (if required)
- Radiator flush (if required)

Warranty Labor

- Oil cooler R&R per OEM SRT
- PTO cover R&R per OEM SRT
- Engine flush (if needed) 1.5 hrs
- Transmission flush (if needed) 1.5 hrs

Warranty Coding

Part: Cooler part number

Complaint: Water leak

Failure: Leaking

Warranty Claim Filing

Reference warranty coverage. File pre-authorized warranty claim through appropriate OEM or through Direct Pay. Reference guideline number RWRG0005 in warranty claim text.

Note: Repairs that exceed parts and labor parameters cannot be pre-authorized.

Pre-Authorized Warranty Repair Guideline RWRG0005

Filing through Direct Pay

Click here for Direct Pay submission guidelines and claim forms:



Parts Disposition

Heat exchangers (coolers) with external leakage can be scrapped.

Heat exchangers (coolers) with internal leakage are required to be shipped to:

U.S. Returns

Eaton Warranty EFLN# 2050W
13100 East Michigan Avenue
Galesburg, MI 49053

Canada Returns:

Eaton Warranty EFLN# 2050W
2160 Williams Parkway
Brampton, Ontario
Canada L6S 5X7

For additional shipping and carrier information, please see Service Bulletin TMIB0129, available on Roadranger.com

Warranty Disclaimer

If the failure is not the result of an accident, damage, negligence, abuse or misuse, improper installation or maintenance or any other conditions described in the Limits and Exclusions section of Warranty Manual TCWY0600, available on Roadranger.com, then Roadranger will treat the condition as covered under its warranty. However, this conclusion does not necessarily mean that a defect in fact exists. In all cases, Roadranger shall make the final determination and interpretation as to the warrantability of the Product.

Pre-Authorized Warranty Repair Guideline RWRG0007

RWRG0007 - Internal heat Exchange (Cooler) Failure

Symptom(s)

- Unexplained engine coolant loss
- Engine coolant in the transmission oil
- Oil pushing out shift tower, rear seal leaking, oil coming out through input shaft cover opening

Warranty Coverage

The warranty coverage varies depending on vehicle vocation. Internal oil cooler coverage is the same as that of its respective transmission coverage including extended warranty. (No restriction on internal cooler.)

Repair Guideline

Internal heat exchangers can be replaced through the bottom of transmission by removing the cooler cover.

Always inspect the condition of the transmission through the cooler opening once cooler is removed. Often times there is no damage and the trans appears clean internally. Only the cooler and oil will need to be replaced.

If the transmission is contaminated it should be flushed with DEXRON ATF. See transmission flush procedure in service bulletin TMIB0124, on Roadranger.com.

If the front box gears are scored or there is apparent transmission damage pull transmission and perform repairs.

Warranty Parts

- K-3246: Internal cooler kit
- 4303742: Cooler gasket
- New lube
- Coolant (if required)
- ATF (if required)
- Engine cleaner (if required)

Warranty Labor

- Oil cooler R&R per OEM SRT
- Trans flush procedure (if needed) 1.5 hrs
- Engine flush (if needed) 1.5 hrs

Warranty Coding

Part: 4303744

Complaint: Water leak

Failure: Leaking

Warranty Claim Filing

Reference warranty coverage. File pre-authorized warranty claim through appropriate OEM or through Direct Pay. Reference guideline number RWRG0007 in warranty claim text.

Note: Repairs that exceed parts and labor parameters cannot be pre-authorized.

Filing through Direct Pay

Click here for Direct Pay submission guidelines and claim forms:



Parts Disposition

Parts are required to be returned.

U.S. Returns:

Eaton Warranty EFLN# 2050W
13100 East Michigan Avenue
Galesburg, MI 49053

Canada Returns:

Eaton Warranty EFLN# 2050W
2160 Williams Parkway
Brampton, Ontario
Canada L6S 5X7

For additional shipping and carrier information, please see Service Bulletin TMIB0129, available on Roadranger.com

Warranty Disclaimer

If the failure is not the result of an accident, damage, negligence, abuse or misuse, improper installation or maintenance or any other conditions described in the Limits and Exclusions section of Warranty Manual TCWY0600, available on Roadranger.com, then Roadranger will treat the condition as covered under its warranty. However, this conclusion does not necessarily mean that a defect in fact exists. In all cases, Roadranger shall make the final determination and interpretation as to the warrantability of the Product.

Pre-Authorized Warranty Repair Guideline RWRG0031

RWRG0031 - Splitter, Cylinder, Dry / Oil Ingestion on 13 - 18 Speeds

Symptom(s)

- Slow or no splitter shifts
- Oil coming from breather on splitter cover

Cause

Complaints of slow splitter shifts can be caused by excessive oil in the splitter cylinder or a dry cylinder.

The machine finish on the splitter bar may not allow the o-ring to properly seal on the splitter bar. Ingested oil in the splitter air system may cause slow splitter shift complaints, as the oil is not able to exhaust quickly through the orifice.

Note: A dry splitter cylinder that was never properly lubricated with silicone during assembly may also produce a slow split complaint. In that case the cylinder should be rebuilt with new o-rings and properly lubricated.

Repair Guideline

Oil in the cylinder:

Rebuild the splitter cylinder with new o-rings. Blow the oil out of the splitter cover and air lines. The splitter cylinder cover should be reused and only replaced if it's slow reacting after the repair.

Dry cylinder:

The cylinder should be rebuilt with new o-rings and properly lubricated.

Specific 13/18-speed model repair guideline:

The splitter cylinder is accessible without auxiliary removal and should be rebuilt with new o-rings when oil ingestion is encountered. Splitter cover should be blown out and reused.

Splitter and mating gear clutch wear, whether due to the continued operation or related to driver technique and is not covered under warranty.

Note: When repairing a unit for oil in the splitter and there has been a verified splitter jump out or slip out complaint (trans becomes disengaged while operating in drive, coast or partial throttle operation) the auxiliary should be removed to replace the failed splitter clutch and mating gear(s). The transmissions inability to stay in gear is a clear indication of badly damaged clutching teeth that must be replaced.

Warranty Parts

- O-ring kit

For part numbers refer to the Eaton InfoRanger site, www.inforanger.roadranger.com, or a current IPL.

Warranty Labor

- Splitter cylinder overhaul per OEM SRT

Warranty Coding

Oil in Cylinder:

Part: 21208

Complaint: Slow splits

Failure: Leaks

Dry Cylinder:

Part: 21209

Complaint: Slow Splitter Shifts

Failure: Lubricant Low

Warranty Claim Filing

Reference warranty coverage. File pre-authorized warranty claim through appropriate OEM or through Direct Pay. Reference guideline number RWRG0031 in warranty claim text.

Note: Repairs that exceed parts and labor parameters cannot be pre-authorized.

Filing through Direct Pay

Click here for Direct Pay submission guidelines and claim forms:



Parts Disposition

Parts can be scrapped.

Warranty Disclaimer

Pre-Authorized Warranty Repair Guideline RWRG0031

If the failure is not the result of an accident, damage, negligence, abuse or misuse, improper installation or maintenance or any other conditions described in the Limits and Exclusions section of Warranty Manual TCWY0600, available on Roadranger.com, then Roadranger will treat the condition as covered under its warranty. However, this conclusion does not necessarily mean that a defect in fact exists. In all cases, Roadranger shall make the final determination and interpretation as to the warrantability of the Product.

Pre-Authorized Warranty Repair Guideline RWRG0032

RWRG0032 - Output Looseness

Symptom(s)

- Vibration
- Noise
- Loose tone wheel
- Rear seal leakage
- Excessive movement of the output shaft

Cause

The output bearing may have started to fail or may have simply become loose.

Repair Guideline

Slight output radial (up and down) looseness is acceptable. If the output system is excessively loose causing a vibration complaint and/or rear seal leak, it should be addressed:

1. Disconnect the driveline and re-torque the nut.
2. If the output movement is eliminated:
 - a. Install a new nut (4306520) and torque it to 650-700 lb-ft. Repair is complete.
3. If the output system is still loose:
 - a. Remove the nut and yoke.
 - b. Clean and lubricate the output shaft splines.
 - c. If the rear seal has been leaking, install a new rear seal and visually inspect the output bearing.
 - d. Reinstall the yoke and nut. Torque to spec.
 - e. If the output movement is eliminated, install a new nut (4306520) and torque it to 650-700 lb-ft. Repair is complete.

Note: After performing the above procedures, if the output system continues not to tighten properly:
See Repair Guideline RWRG-0033 (Output Bearing Failure)

Warranty Parts

- Output nut (4306520)
- Seal kit (if needed)

For part numbers refer to the Eaton InfoRanger site, www.inforanger.roadranger.com, or a current IPL.

Warranty Labor

- Seal replacement time per OEM SRT

Warranty Coding

Part: 4302321

Complaint: Vibration

Failure: Loose

Warranty Claim Filing

Reference warranty coverage. File pre-authorized warranty claim through appropriate OEM or through Direct Pay. Reference guideline number RWRG0032 in warranty claim text.

Note: Repairs that exceed parts and labor parameters cannot be pre-authorized.

Filing through Direct Pay

Click here for Direct Pay submission guidelines and claim forms:



Submission Guidelines and Claim Forms

Parts Disposition

Parts can be scrapped.

Warranty Disclaimer

If the failure is not the result of an accident, damage, negligence, abuse or misuse, improper installation or maintenance or any other conditions described in the Limits and Exclusions section of Warranty Manual TCWY0600, available on Roadranger.com, then Roadranger will treat the condition as covered under its warranty. However, this conclusion does not necessarily mean that a defect in fact exists. In all cases, Roadranger shall make the final determination and interpretation as to the warrantability of the Product.

Pre-Authorized Warranty Repair Guideline RWRG0032

Pre-Authorized Warranty Repair Guideline RWRG0034

RWRG0034 - Output Seal Leakage

Symptom(s)

- Oil is leaking (wetness/dripping) from the seal area

Note: Weeping/dampness is not a cause for seal replacement.

Cause

- Cocked Seal: This occurs when the seal is mis-installed and not properly seated.
- Spring Escaped: Improper installation tool, excessive force used to install.
- Sleeve Leaks: The sleeve or output yoke seal surface is machined incorrectly or damaged.
- Seal Torn: Possible installation damage
- Seal Worn: The cross hatching on the seal lip has worn away with use.
- Seal has loose fit in bearing cover.

Repair Guideline

Carefully remove the seal, inspect the mating surface for any damage. Make sure there is a snug fit between the O.D. of the seal and the cover. If any component of the seal system is damaged address the damage and install a new seal with proper driver.

Warranty Parts

- Rear seal kit
- Output nut

For part numbers refer to the Eaton InfoRanger site, www.inforanger.roadranger.com, or a current IPL.

Warranty Labor

- Seal replacement labor per OEM SRT

Warranty Coding

Part: 4302322

Complaint: Oil leak

Failure: Leaking

Warranty Claim Filing

Reference warranty coverage. File pre-authorized warranty claim through appropriate OEM or through Direct Pay. Reference guideline number RWRG0034 in warranty claim text.

Note: Repairs that exceed parts and labor parameters cannot

be pre-authorized.

Filing through Direct Pay

Click here for Direct Pay submission guidelines and claim forms:



Parts Disposition

Parts can be scrapped.

Warranty Disclaimer

Rear seal repairs are covered under warranty except for the following exceptions:

1. The failure is the result of an improper prior repair or any other conditions described in the Limits/Exclusions section of Warranty Manual TCWY0600, available on Roadranger.com.
2. A maximum of three seals will be covered for the life of the transmission.
3. Rear seal leaks on Reman transmissions are not covered.

If the failure is not the result of an accident, damage, negligence, abuse or misuse, improper installation or maintenance or any other conditions described in the Limits and Exclusions section of Warranty Manual TCWY0600, available on Roadranger.com, then Roadranger will treat the condition as covered under its warranty. However, this conclusion does not necessarily mean that a defect in fact exists. In all cases, Roadranger shall make the final determination and interpretation as to the warrantability of the Product.

Pre-Authorized Warranty Repair Guideline RWRG0034

Pre-Authorized Warranty Repair Guideline RWRG0040

RWRG0040 - Low Range Synchronizer Failure

Symptom(s)

- Transmission grinds when shifting to low range
- Difficulty shifting to low range; hangs up or very slow to engage when air pressure is to specification

Cause

Material is missing from the low range synchronizer, burned or worn excessively, allowing the range shift to rake.

If the material appears to be stripped off the synchro ring, inspect for a possible heat exchanger failure.

Note: On FR models, the low range synchronizer may bottom in the reduction gear and material may just be glazed.

Repair Guideline

In the event of a material failure the mating gear and low range synchronizer must be replaced, even if the gear looks fine. The range yoke should be re-used unless the yoke pad thickness is worn to less than 0.400 at any point on the pad area. The new synchronizer material must be lubed prior to installation. Check for proper case alignment dowel pin installation. See Service Bulletin TMIB0139, available on Roadranger.com.

Note: Fretted or stepped range clutch teeth, broken blocker pins or broken synchronizers indicate torsional vibration, which is not covered by warranty.

Warranty Parts

- Synchronizer Kit
- Mating Reduction Gear
- Gasket Kit
- Output nut
- Range O-Ring or Piston Kit (if needed)
- Reduction Gear Washer (if needed)
- Seal Kit (if needed)

For part numbers refer to the Eaton InfoRanger site, www.inforanger.roadranger.com, or a current IPL.

Warranty Labor

- Air System Check per OEM SRT
- Auxiliary R&R per OEM SRT
- Bench Time per OEM SRT
- Shift Bar Housing R&R per OEM SRT (required on FR models)

Warranty Coding

Part: A-7254

Complaint: Grinding

Failure: Worn

Warranty Claim Filing

Reference warranty coverage. File pre-authorized warranty claim through appropriate OEM or through Direct Pay. Reference guideline number RWRG0040 in warranty claim text.

Note: Repairs that exceed parts and labor parameters cannot be pre-authorized.

Filing through Direct Pay

Click here for Direct Pay submission guidelines and claim forms:



Parts Disposition

Parts can be scrapped.

Warranty Disclaimer

If the failure is not the result of an accident, damage, negligence, abuse or misuse, improper installation or maintenance or any other conditions described in the Limits and Exclusions section of Warranty Manual TCWY0600, available on Roadranger.com, then Roadranger will treat the condition as covered under its warranty. However, this conclusion does not necessarily mean that a defect in fact exists. In all cases, Roadranger shall make the final determination and interpretation as to the warrantability of the Product.

Pre-Authorized Warranty Repair Guideline RWRG0040

Pre-Authorized Warranty Repair Guideline RWRG0042

RWRG0042 - Air Filter Regulator Failure

Symptom(s)

- Transmission grinds
- Transmission has harsh or slow range or split shifts
- Air leaking at the air filter regulator
- Incorrect air pressure

Cause

Improper air pressure can cause a range or splitter shift problem. Air pressure is 58-63 psi on the air filter regulator. Flaws in the air filter regulator or damaged threads can cause air leaks.

Repair Guideline

If the air pressure is out of specification or leaking air, the air filter regulator should be replaced.

Warranty Parts

- Filter/Regulator Assembly

For part numbers refer to the Eaton InfoRanger site, www.inforanger.roadranger.com, or a current IPL.

Warranty Labor

- Air System Check per OEM SRT
- Filter/Regulator R&R per OEM SRT

Warranty Coding

Part:

- A-5454 Deep Reduction Models
- A-4740 All Other

Complaint: Various

Failure: Broken

Warranty Claim Filing

Reference warranty coverage. File pre-authorized warranty claim through appropriate OEM or through Direct Pay. Reference guideline number RWRG0042 in warranty claim text.

Note: Repairs that exceed parts and labor parameters cannot be pre-authorized.

Filing through Direct Pay

Click here for Direct Pay submission guidelines and claim forms:



**Submission Guidelines
and Claim Forms**

Parts Disposition

Parts are required to be returned.

Ship parts to:

U.S. Returns

Eaton Warranty EFLN# 2050W
13100 East Michigan Avenue
Galesburg, MI 49053

Canada Returns:

Eaton Warranty EFLN# 2050W
2160 Williams Parkway
Brampton, Ontario
Canada L6S 5X7

Note: For additional shipping and carrier information, please see Service Bulletin TMIB0129, available on Roadranger.com

Warranty Disclaimer

If the failure is not the result of an accident, damage, negligence, abuse or misuse, improper installation or maintenance or any other conditions described in the Limits and Exclusions section of Warranty Manual TCWY0600, available on Roadranger.com, then Roadranger will treat the condition as covered under its warranty. However, this conclusion does not necessarily mean that a defect in fact exists. In all cases, Roadranger shall make the final determination and interpretation as to the warrantability of the Product.

Pre-Authorized Warranty Repair Guideline RWRG0042

Pre-Authorized Warranty Repair Guideline RWRG0043

RWRG0043 - High Range Synchronizer Failure

Symptom(s)

- Transmission grinds going into high range when air pressure is to specification

Cause

Material is missing from the high range synchronizer, burned or worn excessively allowing the range shift to rake.

If the material appears to be stripped off the synchro ring, inspect for a possible heat exchanger failure.

Repair Guideline

In the event of a material failure, the mating gear and high range synchronizer must be replaced, even if the gear looks fine. The range yoke should be reused unless the yoke pad thickness is worn to less than .400 at any point on the pad area. The new synchronizer material must be lubed prior to installation.

Check for proper case alignment dowel pin installation. See Service Bulletin TMIB0139.

Note: Fretted or stepped range clutch teeth are an indication of torsional vibration, which is not covered by warranty.

Warranty Parts

- Synchronizer Kit
- Mating Gear
- Gasket Kit
- Output Nut
- Range O-Ring or Piston Kit (if needed)
- Seal Kit (if needed)

If the material appears to be stripped off the synchro ring, inspect for a possible heat exchanger failure.

Warranty Labor

- Air System Check per OEM SRT
- Auxiliary R&R per OEM SRT
- Bench Time per OEM SRT
- Shift Bar Housing R&R per OEM SRT (required on FR models)

Warranty Coding

Part: A-7331

Complaint: Grinding

Failure: Worn

Warranty Claim Filing

Reference warranty coverage. File pre-authorized warranty claim through appropriate OEM or through Direct Pay. Reference guideline number RWRG0043 in warranty claim text.

Note: Repairs that exceed parts and labor parameters cannot be pre-authorized.

Filing through Direct Pay

Click here for Direct Pay submission guidelines and claim forms:



Parts Disposition

Parts can be scrapped.

Warranty Disclaimer

If the failure is not the result of an accident, damage, negligence, abuse or misuse, improper installation or maintenance or any other conditions described in the Limits and Exclusions section of Warranty Manual TCWY0600, available on Roadranger.com, then Roadranger will treat the condition as covered under its warranty. However, this conclusion does not necessarily mean that a defect in fact exists. In all cases, Roadranger shall make the final determination and interpretation as to the warrantability of the Product.

Pre-Authorized Warranty Repair Guideline RWRG0043

Pre-Authorized Warranty Repair Guideline RWRG0060

RWRG0060 - Auxiliary Case to Main Case Gasket Leak

Symptom(s)

- Oil leak toward rear of transmission

Cause

Auxiliary case gasket may leak. Slight dampness or an oil stain would not justify a repair but if wetness or a drip is noticed repairs should be made.

Repair Guideline

The shift tower, shift bar housing and auxiliary section must be removed. All gasket surfaces should be cleaned and new gaskets installed.

Warranty Parts

- Gaskets
- Top off oil (up to \$30 if needed)
- Strap bolts (if needed)

For part numbers refer to the Eaton InfoRanger site, www.inforanger.roadranger.com, or a current IPL.

Warranty Labor

- Shift bar housing R&R per OEM guideline
- Auxiliary section R&R per OEM guideline

Warranty Coding

- Part: 4302248
- Complaint: Oil leak
- Failure: Leaks

Warranty Claim Filing

Reference warranty coverage. File pre-authorized warranty claim through appropriate OEM or through Direct Pay. Reference guideline number RWRG0060 in warranty claim text.

Note: Repairs that exceed parts and labor parameters cannot be pre-authorized.

Filing through Direct Pay

Click here for Direct Pay submission guidelines and claim forms:



Parts Disposition

Parts can be scrapped.

Warranty Disclaimer

If the failure is not the result of an accident, damage, negligence, abuse or misuse, improper installation or maintenance or any other conditions described in the Limits and Exclusions section of Warranty Manual TCWY0600, available on Roadranger.com, then Roadranger will treat the condition as covered under its warranty. However, this conclusion does not necessarily mean that a defect in fact exists. In all cases, Roadranger shall make the final determination and interpretation as to the warrantability of the Product.

Pre-Authorized Warranty Repair Guideline RWRG0060

Roadranger Warranty Repair Guideline RWRG0001

RWRG0001 - Auxiliary Drive Gear Bearing Failure

Symptom(s)

- Growl noise only in low range, subsides in High range
- Lever moves fore and aft during acceleration and deceleration
- Lever jumps out (especially in reverse)

Cause

The auxiliary drive gear bearing can become pitted, loose and ultimately fail. Worse-case scenario is when the bearing cage breaks up. This can allow the auxiliary drive gear to be thrust for and aft causing additional damage to the main or auxiliary sections.

Repair Guideline

When the above complaint has been verified the transmission main box should be inspected through a PTO opening.

There are two levels of repair for a failed Auxiliary Drive Gear Bearing:

Repair Level 1:

If no bearing pieces are found through the PTO opening and the bearing cage is intact, pull auxiliary only to replace the failed bearing.

Repair Level 2:

If bearing cage pieces or balls are found through the PTO opening, the complete transmission should be removed. The mainshaft should be pulled, stripped down and inspected for possible gear hub or washer damage. The main case should be cleaned. The auxiliary section may only require flushing but should be visually inspected for damage.

Repair Strategy for Auxiliary section:

Visually inspect auxiliary countershaft front bearings for pitting, spalling, or severe debris dent damage (detectable by feel). These bearings are readily visible with the auxiliary removed. If there is no pitting on the rollers or races and the races (cups) have only a dull polish, light scratching or slight debris dents that cannot be detected with a fingernail while going around the race (not across it), they can be reused. If bearings are acceptable based on inspection, flush auxiliary section and reinstall.

Note: When pitting/spalling exists - disassemble auxiliary to replace auxiliary countershaft bearings and inspect remaining components.

Warranty Labor

Repair level 1:

Auxiliary R&R per OEM SRT

Bench Repair time for cleaning and bearing replacement - 1.0 hour

PTO cover R&R for inspection per OEM SRT

Repair level 2:

Transmission R&R per OEM SRT

Mainshaft overhaul bench time per OEM SRT

Warranty Coding

Part: 5566508

Complaint: Noise

Failure: Bearing failure

Warranty Disclaimer

If the failure is not the result of an accident, damage, negligence, abuse or misuse, improper installation or maintenance or any other conditions described in the Limits and Exclusions section of Warranty Manual TCWY0600, then Roadranger will treat the condition as covered under its warranty. However, this conclusion does not necessarily mean that a defect in fact exists. In all cases, Roadranger shall make the final determination and interpretation as to the warrantability of the Product.

Roadranger Warranty Repair Guideline RWRG0002

RWRG0002 - Auxiliary Countershaft Bearing Failure

Symptom(s)

- Excessive fine metal suspended in the oil
- Constant whine or growl noise in all gears, subsides in neutral
- Road speed related noise (mph) not rpm
- Noise changes from low to hi range
- Auxiliary jump out
- Excessive transmission sump-operating temperature

Cause

Auxiliary countershaft bearing failure can occur due to overloading, lack of lubrication* or improper prior repairs.

Repair Guideline

Once the complaint is confirmed and before removing the transmission, pull the 8 bolt PTO cover and inspect for broken pieces and gear teeth damage in the front section. If scoring or gear teeth discoloration is noted through the PTO opening this is an indication of a low-lube failure. If the front box inspection through the PTO opening shows no signs of secondary damage pull the auxiliary section to make repairs.

Note: Once apart, case bearing bore damage may be found requiring front section removal and main case replacement.

Maximum bearing race to bore clearance allowable - 0.004".

Warranty Labor

- Auxiliary R&R per OEM SRT
- Two speed Auxiliary overhaul (bench) per OEM SRT
- SBH R&R (For FR models) per OEM SRT
- Multi-speed Auxiliary overhaul (bench) per OEM SRT
- Transmission R&R (only if needed) per OEM SRT

Warranty Coding

Part: 4302074 or 4301851 (Bearing)

Complaint: Noise

Failure: Spalled

Warranty Disclaimer

If the failure is not the result of an accident, damage, negligence, abuse or misuse, improper installation or maintenance or any other conditions described in the Limits and Exclusions section of Warranty Manual TCWY0600, available on Roadranger.com, then Roadranger will treat the condition as covered under its warranty. However, this conclusion does not necessarily mean that a defect in fact exists. In all cases, Roadranger shall make the final determination and interpretation as to the warrantability of the Product.

Roadranger Warranty Repair Guideline RWRG0002

Roadranger Warranty Repair Guideline RWRG0003

RWRG0003 - Auxiliary Drive Gear Bearing Failure

Symptom(s)

- Growl noise only in low range, subsides in hi range
- Lever moves fore and aft during acceleration and deceleration
- Lever jumps out (especially in reverse)

Cause

The auxiliary drive gear bearing can become pitted, loose and ultimately fail. Worst-case scenario is when the bearing cage breaks up. This can allow the Auxiliary Drive Gear to be thrust fore and aft causing additional damage to the main or auxiliary sections.

Repair Guideline

When the above complaint has been verified the transmission main box should be inspected through a PTO opening.

There are two levels of repair for a failed Auxiliary Drive Gear Bearing:

Level 1: If no bearing pieces are found through the PTO opening and the bearing cage is intact, pull auxiliary only to replace the failed bearing.

Level 2: If bearing cage pieces or balls are found through the PTO opening, the complete transmission should be removed. The mainshaft should be pulled, stripped down and inspected for possible gear hub or washer damage. The main case should be cleaned. The auxiliary section may only require flushing but should be visually inspected for damage.

Note: Repair Strategy for Auxiliary section:

Visually inspect auxiliary countershaft front bearings for pitting, spalling, or severe debris dent damage (detectable by feel). These bearings are readily visible with the Auxiliary removed. If there is no pitting on the rollers or races and the races (cups) have only a dull polish, light scratching or slight debris dents that cannot be detected with a fingernail while going around the race (not across it), they can be reused. If bearings are acceptable based on inspection, flush auxiliary section and reinstall.

When pitting/spalling exists - disassemble auxiliary to replace Auxiliary countershaft bearings and inspect remaining components.

Warranty Labor

Repair level 1: Auxiliary R&R per OEM SRT

Bench Repair time for cleaning and bearing replacement 1.0 hour

PTO cover inspection per OEM SRT

Shift Bar housing R&R per OEM SRT

Repair level 2: Transmission R&R per OEM SRT

Mainshaft overhaul bench time per OEM SRT

Warranty Coding

Part: 5566504

Complaint: Noise

Failure: Bearing failure

Warranty Disclaimer

If the failure is not the result of an accident, damage, negligence, abuse or misuse, improper installation or maintenance or any other conditions described in the Limits and Exclusions section of Warranty Manual TCWY0600, then Roadranger will treat the condition as covered under its warranty. However, this conclusion does not necessarily mean that a defect in fact exists. In all cases, Roadranger shall make the final determination and interpretation as to the warrantability of the Product.

Roadranger Warranty Repair Guideline RWRG0006

RWRG0006 - Air Module Failure

Symptom(s)

- Constant air leak from module base exhaust
- No or slow range shift into high (shifts properly into low range)
- No or slow range shift into low (shifts properly into high range)

Cause

There are different failure modes involving the A-6342 some are actually caused by other systems that interact with the air module. It is very important to accurately diagnose the module in order to avoid wasting time and money. Make sure to check all air fittings.

Repair Guideline

Air Leak from Module:

Perform the following isolation test procedure in order to diagnose a constant air leak at the range module.

With shift knob air lines still connected, remove module from the transmission and seal off the two small air passages underneath the module with a bolt, nut, flat washer and a piece of gasket material (see Air Module Isolation illustration).

Supply a minimum of 90 psi to the module inlet port. Move the range lever on the shift knob in and out of high and low range. If the module has a constant air leak from the exhaust port located under the module base, the module has failed the test. If no air leaks are detected, the module passes the test. This means the most likely source of the air leak is from the range cylinder piston seals.

Air Module Isolation

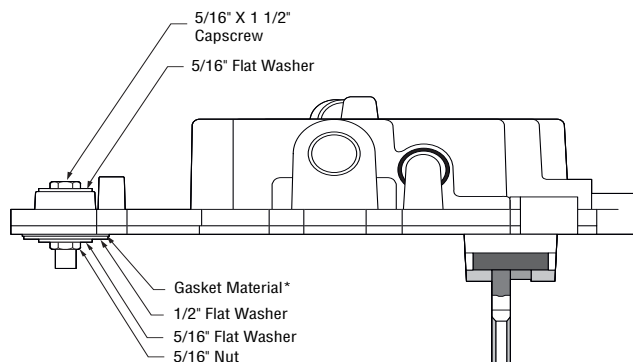

* Gasket material must be used to seal the two holes in the bottom of air module.

With module still mounted, install a 0-100 psi test gauge in each high (H) and low (L) test port on top of the module. Supply a minimum of 90 psi to the module inlet port and operate the range lever between high and low range. Slow response in either direction or a pressure reading outside the 75-85 psi range equals a failed module.

If troubleshooting steps indicate the module is defective or the regulated pressure is out of range (75-85 psi), replace the module as a unit. The module is not a serviceable unit.

Warranty Labor

- Module R&R per OEM SRT

Warranty Coding

Part: A-6342 (Module)

Complaint: Won't shift or leaking

Failure: Broken or leaking

Warranty Disclaimer

If the failure is not the result of an accident, damage, negligence, abuse or misuse, improper installation or maintenance or any other conditions described in the Limits and Exclusions section of Warranty Manual TCWY0600, available on Roadranger.com, then Roadranger will treat the condition as covered under its warranty. However, this conclusion does not necessarily mean that a defect in fact exists. In all cases, Roadranger shall make the final determination and interpretation as to the warrantability of the Product.

No or Slow Range Shift in Either Direction:

Roadranger Warranty Repair Guideline RWRG0012

RWRG0012 - Range Yoke Snap Ring Failure

Symptom(s)

- Transmission will not range shift to either high or low range.
- Stuck in high or low range.

Cause

This transmission uses snap rings to attach the range yoke to the yoke bar in the auxiliary section. When one of the two snap rings fail, the transmission will be unable to range shift.

Repair Guideline

The technician should check the air module outputs to make sure it is shifting the range piston. Air pressure on the H or L port should be (75-85) PSI. Usually an audible click can be heard when attempting to shift ranges. The shift bar housing must be removed to release the range bar. The auxiliary section must be removed to replace both snap rings and if required, the range yoke. At this time the synchronizer should be visually checked for damage or excessive wear.

Take caution not to over stretch either snap ring when installing them onto the range yoke bar.

Warranty Labor

- Shift Bar Housing R&R per OEM SRT
- Auxiliary R&R per OEM SRT
- Bench time to replace yoke/snap rings .5 hr

Warranty Coding

Part: 4302080 Snap ring

Complaint: Won't shift

Findings: Broken

Warranty Disclaimer

If the failure is not the result of an accident, damage, negligence, abuse or misuse, improper installation or maintenance or any other conditions described in the Limits and Exclusions section of Warranty Manual TCWY0600, then Roadranger will treat the condition as covered under its warranty. However, this conclusion does not necessarily mean that a defect in fact exists. In all cases, Roadranger shall make the final determination and interpretation as to the warrantability of the Product.

Roadranger Warranty Repair Guideline RWRG0016

RWRG0016 - Front Countershaft Bearing Failure

Symptom(s)

- Low frequency noise described as a rumble or growl audible at all speeds and in neutral; may change with engine speed
- Fine metal present in oil

Cause

Front box, front countershaft bearing failure

Background

In late fall 2000 a forced lube oiling system was introduced on 1600 lb-ft and above 13/18 speeds (earlier on 2000 and 2200 lb ft units). The Forced Lube System flows lube through the front countershaft bearings extending their life. Failures have dropped in frequency since then. In March 2002 Enhanced Lube kits were developed to install on units in service without the forced lube system.

See service bulletin TMIB0135 for more information on the enhanced lube kits.

Repair Guideline

Failed bearing is partially pitted - contamination is not severe - minor failure.

Partially pitted

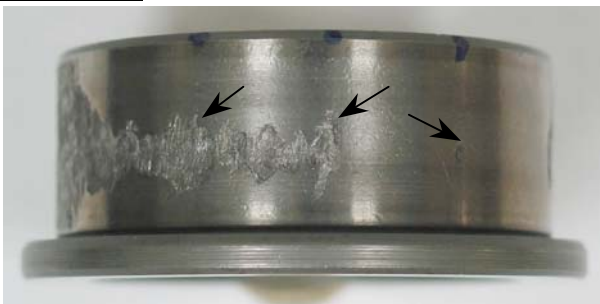

Repair Guideline - Minor:

- Replace 4 C/S bearings only, gaskets and oil.
- Re-use input bearing, inspect/re-use auxiliary drive gear bearing.
- Auxiliary section to be flushed/inspected only not disassembled.

If race has the entire surface damaged, contamination is severe - major failure.

Severally pitted, race worn down



Repair Guideline - Major:

- Replace 4 C/S bearings.
- Replace input shaft bearing.
- Clean/inspect replace auxiliary. drive gear bearing if pitting is found on the races.
- Auxiliary section to be flushed/inspected only not disassembled*.
- Mainshaft should be disassembled and damaged parts replaced.
- The input bushing will generally be damaged and can be replaced if bore in the input shaft is not damaged.

Note: If the transmission is not equipped with a forced lube system (prior to fall 2000) install an Enhanced Lube Kit. Warranty recommends use of the minor kits while purchasing the required bearings separately. For more detail on Enhanced Lube Kits see service bulletin TMIB0135.

*Repair Guideline for Auxiliary section:

Visually inspect auxiliary countershaft front bearings for pitting, spalling, or severe debris dent damage (detectable by feel). These bearings are readily visible with the auxiliary removed. If there is no pitting on the rollers or races and the races (cups) have only a dull polish, light scratching or slight debris dents that cannot be detected with a fingernail while going around the race (not across it), they can be reused. If bearings are acceptable based on inspection, flush auxiliary section and reinstall.

When pitting/spalling exists, disassemble auxiliary to replace auxiliary countershaft bearings and inspect remaining components.

See examples of re-use/replace bearings:

Roadranger Warranty Repair Guideline RWRG0016

Dull polish, light debris dents, no pitting.

Re-use



Warranty Labor

- Labor to R&R transmission per OEM SRT
- Labor for Mainshaft overhaul per OEM SRT
- OR -
- Labor for Complete overhaul, only if required, per OEM SRT

Warranty Coding

Part: 4304599 (bearing)

Complaint: Noise

Failure: Bearing Failure

Spalling on races, pitting on rollers

Replace



Warranty Disclaimer

If the failure is not the result of an accident, damage, negligence, abuse or misuse, improper installation or maintenance or any other conditions described in the Limits and Exclusions section of Warranty Manual TCWY0600, then Roadranger will treat the condition as covered under its warranty. However, this conclusion does not necessarily mean that a defect in fact exists. In all cases, Roadranger shall make the final determination and interpretation as to the warrantability of the Product.

Replace



Roadranger Warranty Repair Guideline RWRG0017

RWRG0017 - Front Countershaft Bearing Failure

Symptom(s)

- Low frequency noise described as a rumble or growl audible at all speeds and in neutral; may change with engine speed
- Fine metal present in oil

Cause

Front box countershaft bearing failure.

Repair Guideline

- Replace all 4 C/S bearings.
- Clean/inspect auxiliary drive gear bearing. If pitting is found on the races, replace.
- Auxiliary section to be flushed/inspected only not disassembled*.
- Mainshaft should be disassembled and damaged parts replaced.
- The input bushing will generally be damaged and can be replaced if bore in the input shaft is not damaged.

*Repair Guideline for Auxiliary section:

Visually inspect auxiliary countershaft front bearings for pitting, spalling, or severe debris dent damage (detectable by feel). These bearings are readily visible with the auxiliary removed. If there is no pitting on the rollers or races and the races (cups) have only a dull polish, light scratching or slight debris dents that cannot be detected with a fingernail while going around the race (not across it), they can be reused. If bearings are acceptable based on inspection, flush auxiliary section and reinstall.

When pitting/spalling exists, disassemble auxiliary to replace auxiliary countershaft bearings and inspect remaining components.

See examples of re-use/replace bearings:

Dull polish, light debris dents, no pitting.

Re-use

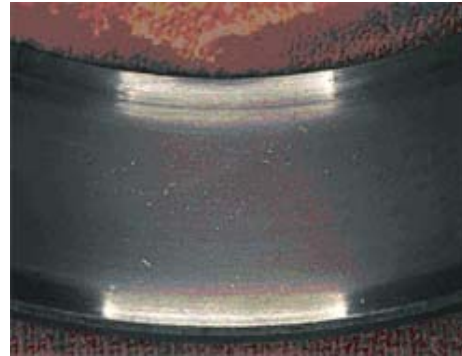

Spalling on races, pitting on rollers

Replace



Replace



Warranty Labor

- Labor to R&R transmission per OEM SRT
- Labor for mainshaft overhaul per OEM SRT

Roadranger Warranty Repair Guideline RWRG0017

- OR -

- Labor for complete overhaul, if required, per OEM SRT

Warranty Coding

Part: 4304080 (bearing)

Complaint: Noise

Failure: Bearing Failure

Warranty Disclaimer

If the failure is not the result of an accident, damage, negligence, abuse or misuse, improper installation or maintenance or any other conditions described in the Limits and Exclusions section of Warranty Manual TCWY0600, then Roadranger will treat the condition as covered under its warranty. However, this conclusion does not necessarily mean that a defect in fact exists. In all cases, Roadranger shall make the final determination and interpretation as to the warrantability of the Product.

Roadranger Warranty Repair Guideline RWRG0018

RWRG0018 - Front Section Countershaft Loose Gears

Symptom(s)

- Auxiliary jump out complaints
- Hard lever shift in the front box
- Input bushing destroyed

Cause

During recent years RTW has noticed transmissions built with a countershaft to gear fitness issue. This is typically a high mileage failure.

Repair Guideline

If the auxiliary jump out complaint is verified and air system defects have been ruled out, the auxiliary section should be removed for inspection. With the auxiliary pulled inspect all clutching parts. If there is fretting on hi range side of the range clutch and the mating gear (see figures 1 & 3) some extra steps must be taken to verify if this damage is a result of external vibration or possibly a loose C/S gear.

Note: Fretting wear to auxiliary clutching teeth may be the result of an external vibration or a loose front box countershaft gear.

When fretting damage is present both PTO covers (and/or PTO) should be removed to check for loose countershaft drive or overdrive gears. A failed input shaft bushing is another indication of loose gears.

If a loose C/S gear is found, the front box must be disassembled to press the gears off each countershaft and check for a broken/worn countershaft key, gear hub or countershaft assembly (figure 2). All damaged parts should be replaced.

Check the rear end of the front box mainshaft splines (see figure 4).

Secondary Damage From Loose Gears



Figure 1: Fretting damage on the auxiliary drive gear clutching teeth.



Figure 2: Fretting damage (wear) on countershaft from a loose gear.

Roadranger Warranty Repair Guideline RWRG0018

Complaint: Various (Noise, Vibration, Oil Leak or Grinds/Rakes)

Failure: Loose



Figure 3: Fretting damage on range clutch on high side.



Figure 4: Fretting damage to end of front box mainshaft.

Warranty Labor

- Transmission R&R per OEM SRT
- Bench labor for front box overhaul repairs per OEM SRT
- OR -
- Bench labor for complete trans overhaul per OEM SRT

Warranty Coding

Part: 19673 (C/S Key)

Warranty Disclaimer

If the failure is not the result of an accident, damage, negligence, abuse or misuse, improper installation or maintenance or any other conditions described in the Limits and Exclusions section of Warranty Manual TCWY0600, then Roadranger will treat the condition as covered under its warranty. However, this conclusion does not necessarily mean that a defect in fact exists. In all cases, Roadranger shall make the final determination and interpretation as to the warrantability of the Product.

Roadranger Warranty Repair Guideline RWRG0020

RWRG0020 - Lever Entrapment / Lever Escapes From Shift Blocks

Symptom(s)

- Transmission is stuck in gear but the lever is in neutral or completely out of the shift blocks (able to move at random)
- Interlock system prevents transmission from going into another gear position

Cause

Sometimes the shift lever tip is able to pass between the lugs on the shift blocks or yokes and escapes its intended position. The lever can end up in neutral or outside the gates, with the transmission is still in gear.

Repair Guideline

Remove the shift tower noting the position of the lever tip and see if a shift yoke is in gear. If this is a newer unit verify the lever is correct for the tower in use. Ask the operator which lever position they were attempting when the lever became entrapped. Inspect for witness marks on the sides of the shift block to see if the lever tip extends the proper depth into the shift block or yoke.

On an older unit a worn shift tower is the most likely cause. It could allow the shift lever to ride too high in the shift blocks enabling the lever to escape the blocks. Because of the tapered end of the lever tip, the higher the lever rides, the easier it is to become entrapped.

Also inspect for a larger space between any two of the shift blocks when compared to the others by lightly prying them apart. If the space is large enough for the lever tip to pass through the blocks and or yokes, they and the corresponding shift rails affecting that gear position should be replaced to correct the condition.

1. If the tower is worn replace it. Install a cast iron replacement if possible.
2. If the lever is worn at the ball or tip replace it.
3. If excessive shift block spacing is present, replace the affected parts. It may include 2 blocks, 2 yokes and 2 shift rails depending on the Transmission model and position the lever was in when the entrapment occurred.

Warranty Labor

- Shift Bar Housing R&R per OEM SRT
- Shift Bar Housing Overhaul per OEM SRT

Warranty Coding

Part: Various

Complaint: Lever Entrapment

Failure: Worn

Warranty Disclaimer

If the failure is not the result of an accident, damage, negligence, abuse or misuse, improper installation or maintenance or any other conditions described in the Limits and Exclusions section of Warranty Manual TCWY0600, then Roadranger will treat the condition as covered under its warranty. However, this conclusion does not necessarily mean that a defect in fact exists. In all cases, Roadranger shall make the final determination and interpretation as to the warrantability of the Product.

Roadranger Warranty Repair Guideline RWRG0027

RWRG0027 - Input Shaft Breakage

Symptom(s)

- Truck won't move

Cause

Input shaft is broken.

Background

Input shaft failures most often begin with a crack in the root of the splines and propagate at a 45-degree angle. The crack initiates and grows through the hardened outer layer of shaft material when high torque impacts occur. These cracks are generated with a high torque spike above 4500 lb-ft. After the initial crack(s) they can grow through normal driving conditions and shaft will eventually break entirely.

Repair Guideline

Depends on the extent of damage found. A broken input shaft may cause secondary damage to the input bearing, bearing bore, gears and master clutch.

Note: This failure mode can result in engine crankshaft or thrust bearing damage. Endplay should be checked per manufacturer's specification.

Warranty Statement

This is a non-warrantable failure.

Note: May be considered warrantable on UltraShift models.

If the customer or Eaton field representative requests further inspection of the failed part, the dealer can file a claim through normal warranty channels, return parts for inspection and receive final disposition.

Pictures of non-warrantable failures:



Non-warrantable failure; claim can be sent in through normal warranty for review if requested.

Roadranger Warranty Repair Guideline RWRG0033

RWRG0033 - Output Bearing Failure

Symptom(s)

- Vibration
- Noise
- Rear seal leakage
- Auxiliary slip out
- Raking on range shifts or
- Excessive movement of the output shaft

Cause

The output bearing may have started to pit, become loose or failed. There may be signs of heat on the inner bearing. The cage may have broken and the rollers escaped.

Background

Bearing Failure:

In the early stages of failure, the bearing rollers begin to pit on the ends and/or the races begin to spall. As the damage continues, the bearing loosens and ultimately fails. Sometimes heat results and the bearing can become darkened from heat.

Note: Output bearings can fail due to lack of lube. Verify by inspecting the transmission gearing. If there are signs of low lube damage on the base box or auxiliary section gear teeth, the failure is determined to be the result of a low lube condition and is not covered under warranty. Excessive vibration from other driveline problems can result in an output bearing failure also.

Output Bearing Flange Breakage:

Manufacturing tolerances of the bearing flange and bearing cover can result in too little flange clamp allowing bearing race movement. This can result in a broken output-bearing flange. Vehicle driveline failures can cause the flange to break too. Most failures result in a failed synchronizer and are bought in with a raking complaint.

In March 2005, improvements went into affect including a new rear bearing cover design* and a new edge molded rear bearing cover gasket. Production units will include a tag under one of the rear bearing cover fasteners identifying the updated cover and instructing the use of gasket part number 1009551 only.

*The counter bore on the old style cover had a depth of 0.1460-.149". Current spec is 0.117-0.120".

Repair Guideline

Upon disassembly, inspect the auxiliary for damage. If the bearing has spun in the bore, check the clearance between the new bearing outer race and the auxiliary case. If it exceeds .004", the case should be replaced.

For flange breakage failures, the rear bearing cover should be updated to the new design. When ordering the old bearing cover part number, it will be replaced by the new p/n with the new gasket included.

Note: New gasket part number 1009551 must not be used with the old style bearing cover, nor should the old gasket part number 4302247 be used with the new design cover.

Warranty Labor

- Auxiliary R&R per OEM SRT
- Auxiliary Overhaul per OEM SRT

Warranty Coding

Part: 5556503

Complaint: Vibration, oil leak or grinds

Failure: Spalled or broken

Warranty Disclaimer

If the failure is not the result of an accident, damage, negligence, abuse or misuse, improper installation or maintenance or any other conditions described in the Limits and Exclusions section of Warranty Manual TCWY0600, then Roadranger will treat the condition as covered under its warranty. However, this conclusion does not necessarily mean that a defect in fact exists. In all cases, Roadranger shall make the final determination and interpretation as to the warrantability of the Product.

Roadranger Warranty Repair Guideline RWRG0037

RWRG0037 - Towing Damage

Symptom(s)

- Hard lever shifts
- Lever movement
- Unable to shift front box gears

Cause

The transmission mainshaft is allowed to spin at high RPMs when a vehicle is towed with the drive wheels on the ground, axle shafts or drive shaft still connected, main box in neutral and engine off. In this condition the majority of the oil has moved to the auxiliary section and the front box gearing is not rotating. Generally the auxiliary section will be in low range and as the unit is “back-driven” the speed of the mainshaft is multiplied by the ratio of the reduction gearing (usually 2.5 times). Coasting in neutral can cause similar damage.

The combination of high mainshaft RPMs, minimal lube splash in the front box, and stationary front box gearing sets the stage for a transmission failure. Damage can occur to the mainshaft gears and washers of any style or design. The washers can show evidence of heat, and ultimately fail breaking the mainshaft key.

Towing a vehicle from the front for any distance without first removing the drive shaft or axles is not recommended. Only when the vehicle is towed by the rear with the drive tires off the ground can you leave the axle shafts or drive shaft in place. Warnings are clearly stated in the Driver Instructions and the General Troubleshooting Guide

Warranty Statement

Towing damage is not the result of a product defect and is not a warrantable failure.

Figure 1: Notice the mainshaft pilot wear bias one side due to centrifugal force.

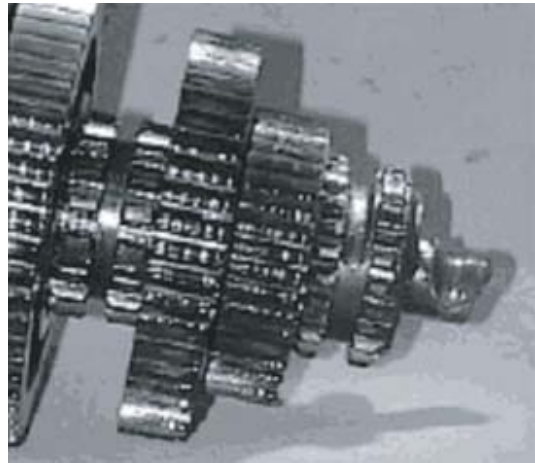

Figure 2: FRO unit overdrive clutch skewed to one side and burned.



Figure 3: Shift yoke burned and broken off from M/S being skewed.



Roadranger Warranty Repair Guideline RWRG0038

RWRG0038 - Transmission Overheating

Symptom(s)

- Transmission sump-operating temperature maintains 250 degrees or greater

Cause

There are several possible causes for the overheating condition including: Cooler flow issue, poor air flow due to cooler location, over-filled/under-filled transmission, a failure to the internal pump or an internal transmission failure.

Note: In every case the transmission temperature gauge should be verified for accuracy.

Repair Guideline

Once the overheating complaint is confirmed and gauge verified, check for noise, shifting trouble or metal in the oil that would indicate a Transmission failure. If no failure is evident and improper fill level has been ruled out, perform a pump flow test.

To verify proper pump flow:

- Oil should be operating temperature.
- Disconnect the return line (lower) from the transmission and position it over a clean 5-gallon pail. Start the truck in neutral and run it at 1500 RPM for 30 seconds.

Note: Pump should flow about 4 GPM @ 1500 RPM. After 30 seconds there should be about 2 gallons of oil in the pail.

- If there is no flow and no restrictions found in the cooling system, the transmission must be disassembled to correct.

Warranty Labor

Pump Test (0.5 hours)

Pump failure RT:

R&R transmission per OEM SRT

Mainshaft overhaul per OEM SRT (generally 4 hrs)

Pump failure FR:

Auxiliary R&R per OEM SRT (generally 3.5 hours)

Shift Bar Housing R&R per OEM SRT (generally 2 hours)

Pump replacement (0.5 hours)

Warranty Coding

Part: Various

Complaint: Overheats

Failure: Broken

Warranty Disclaimer

If the failure is not the result of an accident, damage, negligence, abuse or misuse, improper installation or maintenance or any other conditions described in the Limits and Exclusions section of Warranty Manual TCWY0600, then Roadranger will treat the condition as covered under its warranty. However, this conclusion does not necessarily mean that a defect in fact exists. In all cases, Roadranger shall make the final determination and interpretation as to the warrantability of the Product.

Pre-Authorized Warranty Repair Guideline RWRG0052

RWRG0052 - Broken Spring Cover

Symptom(s)

- Not able to shift transmission into any gear with the vehicle stationary (may have to shut the engine off to shift into gear)
- Vehicle wont move
- Experiencing erratic clutch pedal free-play

Cause

Broken disc damper spring(s).

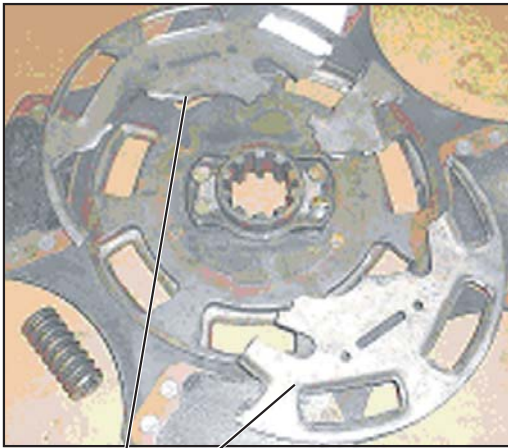

Broken Spring Cover

Repair Guideline

Replace clutch assembly if disc damper spring is broken

Warranty Parts

- Replacement clutch assembly

Warranty Labor

- Clutch and related component R&R per OEM SRTs

Warranty Coding

Part: Clutch installation number (no miscellaneous parts or fly-wheel resurfacing) 108925-14, 108925-80, 108925-82, 108925-85, 108926-14, 108926-80, 108926-82, 108926-85, 109701-14, 109701-80, 109701-82, 109701-85, 109705-14, 109705-80, 109705-82, 109705-85

Primary casual: 023-002-842 (damper springs)

Complaint: Improper release/drag (042)

Failure: Broken/Cracked/Came apart (01)

Warranty Claim Filing

1. Submit Pre-authorized Clutch Claim Form requesting approval.

Required for approval:

- Clutch serial number (date code); see next page for detail on locations.
- Pictures of clutch failure attached to claim submission E-Mail.

Note: Repairs that exceed parts and labor parameters cannot be pre-authorized.

Click here to open Pre-Authorized Clutch Claim Form:



2. Receive pre-approval number or submission denial via email within 1 business day.
3. File approved pre-authorized warranty claim through the appropriate OEM.

Note: Include pre-approval number on warranty claim.

Click here for Direct Pay submission guidelines and claim forms:



Parts Disposition

Hold all replaced parts until notified or payment received.

Pre-Authorized Warranty Repair Guideline RWRG0052

Clutch Serial Number (Date Code) Locations

The clutch serial number (date code) is required for claim approval. The serial number (date code) is stamped in 2 locations on the clutch.

Easy-Pedal - Two places to locate the Serial Number (Date Code):

- Stamped into the clutch cover

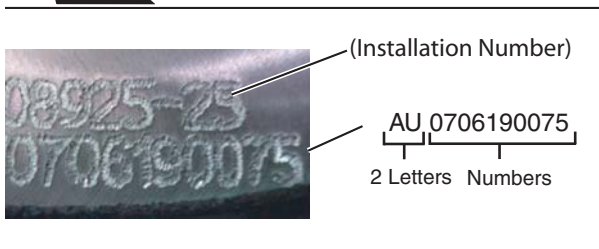

- Stamped in ink on spring cover

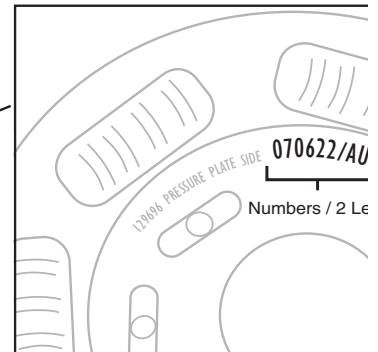

Solo - Two places to locate the Serial Number (Date Code):

- On silver plate on clutch cover

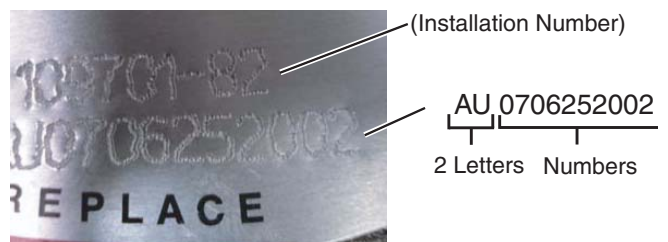

Pre-Authorized Warranty Repair Guideline RWRG0052

- Stamped in ink on spring cover

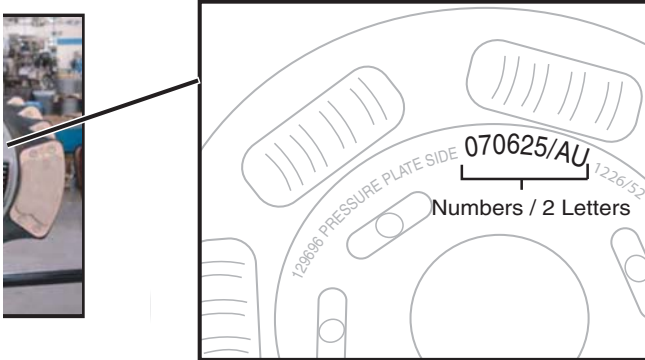

Warranty Disclaimer

If the failure is not the result of an accident, damage, negligence, abuse or misuse, improper installation or maintenance or any other conditions described in the Limits and Exclusions section of Warranty Manual TCWY0600, then Roadranger will treat the condition as covered under its warranty. However, this conclusion does not necessarily mean that a defect in fact exists. In all cases, Roadranger shall make the final determination and interpretation as to the warrantability of the Product.

Pre-Authorized Warranty Repair Guideline RWRG0052

Pre-Authorized Warranty Repair Guideline RWRG0053

RWRG0053 - Broken Damper Spring-7 Spring Damper

Symptom(s)

- Not able to shift transmission into any gear with the vehicle stationary (may have to shut the engine off to shift into gear)
- Vehicle wont move
- Experiencing erratic clutch pedal free-play

Cause

Broken disc damper spring(s).

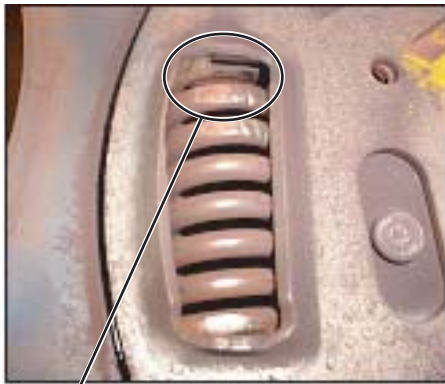

Broken Damper Spring

Repair Guideline

Replace clutch assembly if disc damper spring is broken

Warranty Parts

- Replacement clutch assembly

Warranty Labor

- Clutch and related component R&R per OEM SRTs

Warranty Coding

Part: Clutch installation number (no miscellaneous parts or fly-wheel resurfacing) 208925-14, 208925-80, 208925-82, 208925-85, 209701-14, 209701-80, 209701-82, 209701-85

Primary casual: 023-002-842 (damper springs)

Complaint: Improper release/drag (042)

Failure: Broken/Cracked/Came apart (01)

Warranty Claim Filing

1. Submit Pre-authorized Clutch Claim Form requesting approval.

Required for approval:

- Clutch serial number (date code); see next page for detail on locations.
- Pictures of clutch failure attached to claim submission E-Mail.

Note: Repairs that exceed parts and labor parameters cannot be pre-authorized.

Click here to open Pre-Authorized Clutch Claim Form:



2. Receive pre-approval number or submission denial via E-Mail within 1 business day.
3. File approved pre-authorized warranty claim through the appropriate OEM.

Note: Include pre-approval number on warranty claim. Click here for Direct Pay submission guidelines and claim forms:



Parts Disposition

Hold all replaced parts until notified or payment received.

Pre-Authorized Warranty Repair Guideline RWRG0053

Clutch Serial Number (Date Code) Locations

The clutch serial number (date code) is required for claim approval. The serial number (date code) is stamped in 2 locations on the clutch.

Easy-Pedal - Two places to locate the Serial Number (Date Code):

- Stamped into the clutch cover

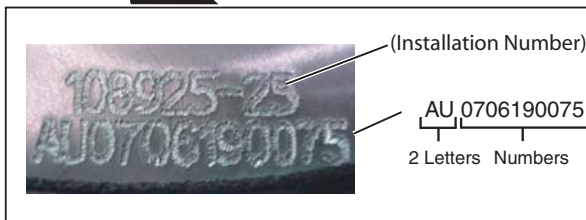

- Stamped in ink on spring cover

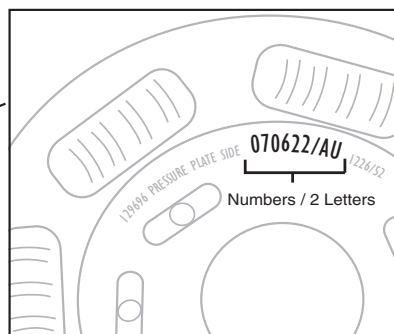

- On silver plate on clutch cover

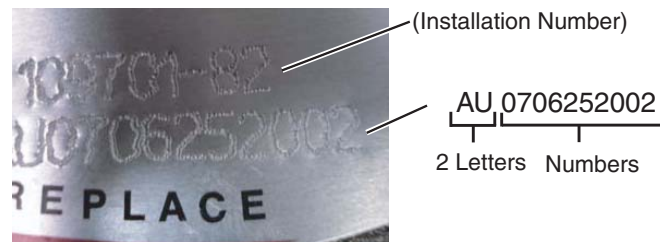
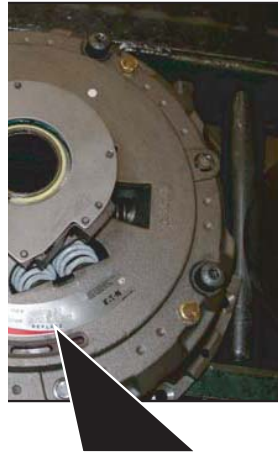

- Stamped in ink on spring cover

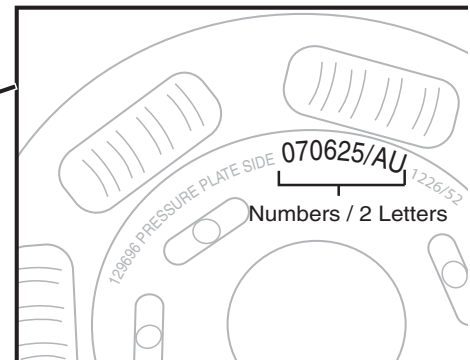

Solo - Two places to locate the Serial Number (Date Code):

Warranty Disclaimer

If the failure is not the result of an accident, damage, negligence, abuse or misuse, improper installation or maintenance or any other conditions described in the Limits and Exclusions section of Warranty Manual TCWY0600, then Roadranger will treat the condition as covered under its warranty. However, this conclusion does not necessarily mean that a defect in fact exists. In all cases, Roadranger shall make the final determination and interpretation as to the warrantability of the Product.

Pre-Authorized Warranty Repair Guideline RWRG0054

RWRG0054 - Broken Hub Rivets-7 Spring Damper

Symptom(s)

- Not able to shift transmission into any gear with the vehicle stationary (may have to shut the engine off to shift into gear)
- Vehicle wont move
- Experiencing erratic clutch pedal free-play

Cause

Broken disc damper hub rivets.



Broken Hub Rivets

Repair Guideline

Replace clutch assembly if the disc damper hub rivets are broken.

Warranty Labor

Clutch and related component R&R per OEM SRTs

Warranty Coding

Part: Clutch installation number (no miscellaneous parts or fly-wheel resurfacing) 208925-14, 208925-80, 208925-82, 208925-85, 209701-14, 209701-80, 209701-82, 209701-85

Primary casual: 023-002-814 (rivets)

Complaint: Improper release/drag (042)

Failure: Broken/Cracked/Came apart (01)

Warranty Claim Filing

1. Submit Pre-authorized Clutch Claim Form requesting approval.

Required for approval:

- Clutch serial number (date code); see next page for detail on locations.
- Pictures of clutch failure attached to claim submission E-Mail.

Note: Repairs that exceed parts and labor parameters cannot be pre-authorized.

Click here to open Pre-Authorized Clutch Claim Form:



2. Receive pre-approval number or submission denial via E-Mail within 1 business day.
3. File approved pre-authorized warranty claim through the appropriate OEM.

Note: Include pre-approval number on warranty claim. Click here for Direct Pay submission guidelines and claim forms:



Parts Disposition

Hold all replaced parts until notified or payment received.

Pre-Authorized Warranty Repair Guideline RWRG0054

Clutch Serial Number (Date Code) Locations

The clutch serial number (date code) is required for claim approval. The serial number (date code) is stamped in 2 locations on the clutch.

Easy-Pedal - Two places to locate the Serial Number (Date Code):

- Stamped into clutch cover

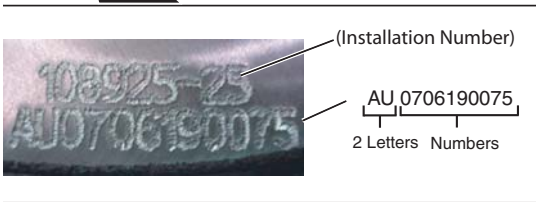

- Stamped in ink on spring cover

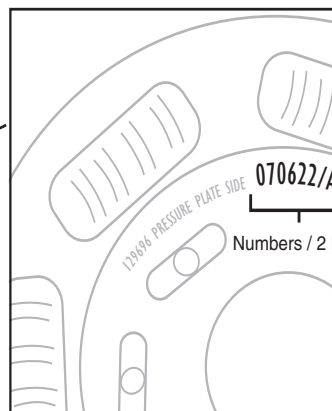

Solo - Two places to locate the Serial Number (Date Code):

- On silver plate on clutch cover

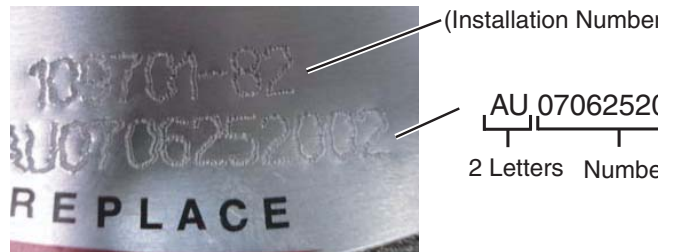
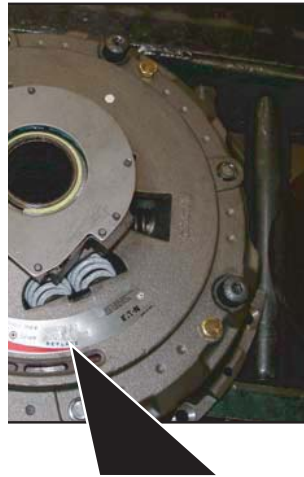

- Stamped in ink on spring cover

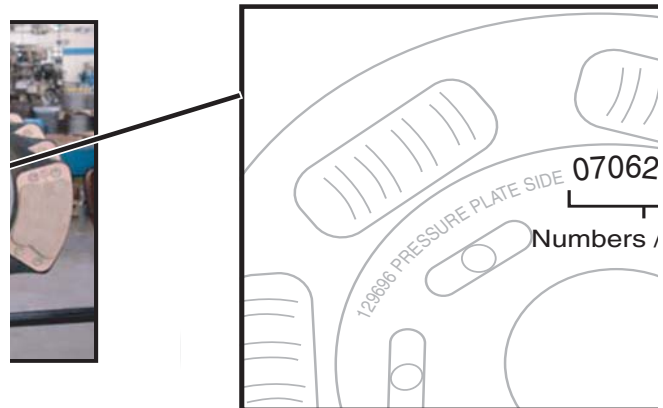

Warranty Disclaimer

If the failure is not the result of an accident, damage, negligence, abuse or misuse, improper installation or maintenance or any other conditions described in the Limits and Exclusions section of Warranty Manual TCWY0600, then Roadranger will treat the condition as covered under its warranty. However, this conclusion does not necessarily mean that a defect in fact exists. In all cases, Roadranger shall make the final determination and interpretation as to the warrantability of the Product.

Roadranger Warranty Repair Guideline RWRG0045

RWRG0045 - Broken Cam Spring

Symptom(s)

- Clutch pedal free-play intermittently changes from no free-play to normal free-play (with possible clutch slippage)
- Not able to shift transmission into any gear while vehicle is stationary; may have to shut engine off to shift into gear
- Clutch doesn't reset properly

Cause

Clutch may have a broken cam spring.

Repair Guideline

To verify the cam spring is broken:

- Depress the clutch pedal
- Move the cam tab back to the left to verify spring tension will pull it back to the right.
- If the cam tab will not return to the right, the cam spring may be broken.

Note: This verification procedure is referenced from the Solo section of service manual CLSM0100. Refer to the manual to view pictures of the procedure.

Warranty Labor

- Clutch and related component R&R per OEM SRTs

Warranty Coding

Part: Clutch installation number (no miscellaneous parts or fly-wheel resurfacing)

Primary casual: 023-002-810 (cam load spring)

Complaint: Improper release/drag (042)

Failure: Broken/Cracked/Came apart (01)

Include clutch serial number (date code) on claim submission.

Clutch Serial Number (Date Code)

The clutch serial number (date code) is required for claim approval. The serial number (date code) is stamped in 2 locations on the clutch.

Solo Clutch - Two places to locate the Serial Number (Date Code):

- Along flat surface or rim area of clutch cover

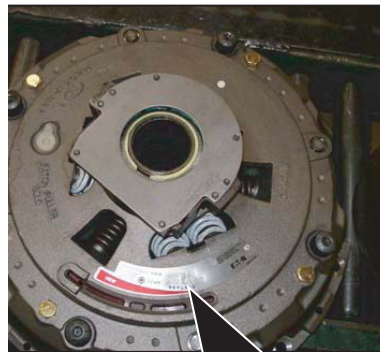

- On spring cover

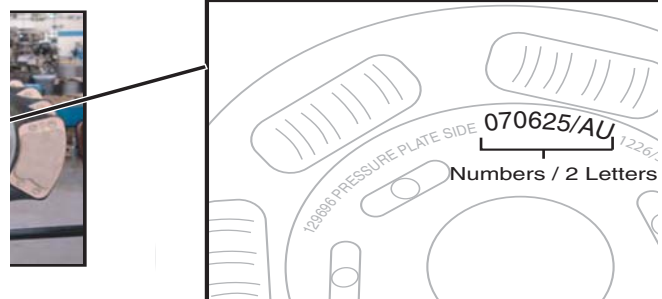

Parts Disposition

Hold all replaced parts until notified or payment received.

Warranty Disclaimer

If the failure is not the result of an accident, damage, negligence, abuse or misuse, improper installation or maintenance or any other conditions described in the Limits and Exclusions section of Warranty Manual TCWY0600, then Roadranger will treat the condition as covered under its warranty. However, this conclusion does not necessarily mean that a defect in fact exists. In all cases, Roadranger shall make the final determination and interpretation as to the warrantability of the Product.

Roadranger Warranty Repair Guideline RWRG0046

RWRG0046 - Idle Rattle

Symptom(s)

- Idle rattle

Cause

Idle rattle or neutral rattle is noise at idle caused by fluctuations in flywheel speed resulting in speed variations at the input shaft. This condition can cause the internal gearing to contact both the drive side and coast side, creating a continuous noise. This idle rattle noise can be identified by slowly raising the engine RPMs, usually between 700 and 1000 RPMs, the noise will diminish or be eliminated. Idle rattle is not a component damaging condition, however it can be very annoying to the operator as it does create a very abnormal noise. Idle rattle can be identified by partially releasing the clutch to see if the noise goes away.

Repair Guideline

Refer to Service Bulletin CLIB0001.

Idle rattle complaints are not the result of defective transmissions or the factory-installed master clutch. If an idle rattle complaint is encountered, the complaint may be resolved by replacing the original front and rear discs with the VCT Plus PD discs only. There is no need to replace the intermediate plate or pressure plate, unless damage or wear requires.

Warranty Statement

This is not a warrantable failure.

Roadranger Warranty Repair Guideline RWRG0047

RWRG0047 - Seized Solo Adjusting Cam

Symptom(s)

- Not enough or no clutch pedal free-play
- No clutch brake
- Clutch slippage
- Unable to shift transmission into gear while vehicle is stationary (may have to shut engine off to shift into gear)

Complaint: Improper release/drag (042)

Failure: Seized (28)

Include the clutch serial number (date code) on claim submission.

Cause

Clutch pedal linkage out of adjustment or self adjusting cam may have stopped adjusting

Repair Guideline

To verify the adjusting cam has seized:

1. Measure distance between release bearing and clutch brake. **Note:** Procedure for measuring found in service manual CLSM0200.
 - If bearing travel is between 0.490 and 0.560, the adjusting cam has not seized. Inspect and adjust clutch pedal linkage.
 - If bearing travel is greater than 0.560, perform seized cam procedure. **Note:** Procedure for seized cam located in service manual CLSM0200. Verify cam is no longer seized by measuring distance between release bearing and clutch (between 0.490 and 0.560).
2. If the bearing travel is greater than 0.560 and the cam tab cannot be moved, request customer authorization to remove clutch and inspect:

Note: If the clutch is overheated (blued/scored) or the cam was seized from heat, the clutch assembly will require replacement, but it is a non-warrantable failure.

3. If the cam tab could not be reset and the clutch is not overheated, the clutch assembly will require replacement and it is a warrantable failure.

Warranty Labor

- Clutch and related component R&R per OEM SRTs

Warranty Coding

Part: Clutch installation number (no miscellaneous parts or fly-wheel resurfacing)

Primary casual: 023-002-811 (cam/tab)

Roadranger Warranty Repair Guideline RWRG0047

Clutch Serial Number (Date Code)

The clutch serial number (date code) is required for claim approval. The serial number (date code) is stamped in 2 locations on the clutch.

Solo Clutch - Two places to locate the Serial Number (Date Code):

- On silver plate on clutch cover

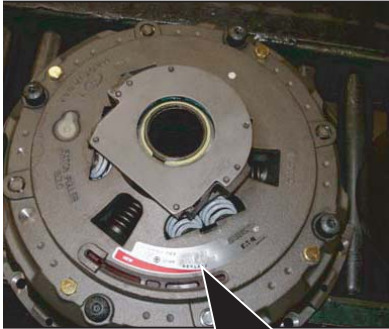

- Stamped in ink on spring cover

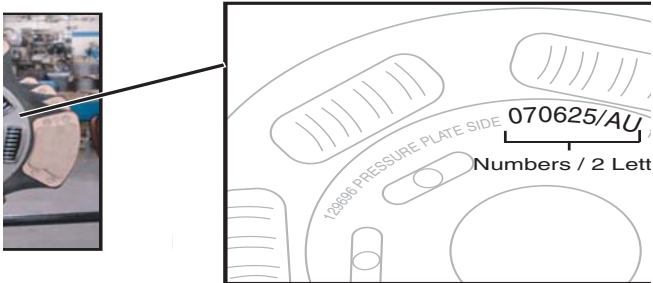

Parts Disposition

Hold all replaced parts until notified or payment received.

Warranty Disclaimer

If the failure is not the result of an accident, damage, negligence, abuse or misuse, improper installation or maintenance or any other conditions described in the Limits and Exclusions section of Warranty Manual TCWY0600, then Roadranger will treat the condition as covered under its warranty. However, this conclusion does not necessarily mean that a defect in fact exists. In all cases, Roadranger shall make the final determination and interpretation as to the warrantability of the Product.

Roadranger Warranty Repair Guideline RWRG0049

RWRG0049 - Broken Intermediate Plate Aluminum Ring

Symptom(s)

- Not be able to shift transmission into any gear while vehicle is stationary; may have to shut the engine off to shift into gear with possible vibration and/or noise

Cause

Broken aluminum ring on the intermediate plate.

Repair Guideline

This guideline applies to OEM installed clutches and OEM dealer installed service part clutches.

Inspect the intermediate plate for correct installation through the clutch housing inspection cover. Refer to service manual CLSM0100 for detailed inspection procedure.

- **Correct Installation:** The drive straps must be facing toward the clutch pressure plate. (With the clutch removed, the aluminum will be marked with "Pressure Plate Side and/or Flywheel Side.") If the aluminum ring is installed correctly and the aluminum ring is broken, replace the clutch assembly.
- **Incorrect Installation:** If the intermediate plate is installed with drive straps toward the flywheel and the aluminum ring is broken, concern was caused by an installation error, non-warrantable.

Warranty Coding

Part: Clutch installation number (no misc. parts or flywheel resurfacing)

Primary casual: 023-002-824 (aluminum spacer ring)

Complaint: Broken (002)

Failure: Broken/Cracked/Came apart (01)

Include the clutch serial number/date code from the clutch assembly or clutch disc

Clutch Serial Number (Date Code) Locations

Solo and Manual Adjust - 2 Serial Number (Date Code) Locations:

- Stamped into flat surface or rim area of clutch cover

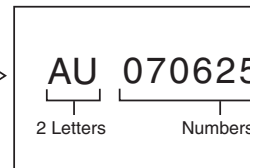

- Stamped on spring cover

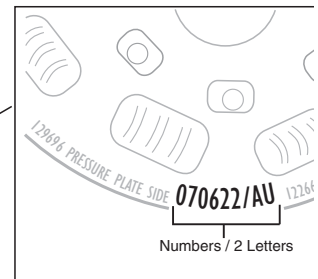

365mm - Serial Number (Date Code) Location:

- Stamped into clutch cover

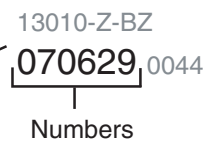

Parts Disposition

Hold all replaced parts until notified or payment received.

Warranty Disclaimer

If the failure is not the result of an accident, damage, negligence, abuse or misuse, improper installation or maintenance or any other conditions described in the Limits and Exclusions section of Warranty Manual TCWY0600, then Roadranger will treat the condition as covered under its warranty. However, this conclusion does not necessarily mean that a defect in fact exists. In all cases, Roadranger shall make the final determination and interpretation as to the warrantability of the Product.

Pre-Authorized Warranty Repair Guideline RWRG0051

RWRG0051 - Splitter Complaint - Fault Code 42

Symptom(s)

A Fault Code 42 with:

- A complaint of transmission only shifting in odd or even gears when splits should occur, or
- Slow splits

Cause

Splitter cylinder walls may become dry or have contamination build up in the cylinder which may cause the piston to move slowly or not at all.

Background

In the early stages there will be evidence of missed splitter shifts causing the driver to have only odd or even gears in the range that can be split. If the condition exists long enough there may be signs of damage to o-rings or splitter solenoid valve. Any evidence of corrosion where the cylinder has a build-up of rust, water and dirt will be cause for claim denial.

Repair Guideline

Perform the trouble shooting steps per the appropriate guide and check for correct air pressures.

STEP A:

1. Key off
2. Install a 0-100 PSI air pressure gauge in the regulated test port of the air filer/regulator.
3. Start engine and allow air pressure to build to governor cut-off.
4. Monitor vehicle air pressure gauge on the dash and if vehicle maintains air pressure go to Step B.

STEP B:

1. If air pressure is 55 to 65 PSI go to Step C.

STEP C:

1. Key off.
2. Install (2) 0-100 PSI air pressure gauges in the splitter cover diagnostic ports.
3. Start vehicle and allow air pressure to build to governor cut-off.

4. Release clutch (AutoShift only) to register input shaft speed in the transmission.
5. Turn off engine but leave the key in the ON position.
6. With Shift Control, select reverse (R1 in gear display for 13/18 speed), and then select neutral. If LOW splitter gauge = 55 to 65 PSI and if HIGH splitter gauge = 0 PSI go to step D:

Note: Five minutes is allowed for checking the air pressure after shifting the transmission to neutral.

STEP D:

1. Key on
2. With Shift Control, select reverse gear (R2 in the gear display for 13/18 speed) by pressing the upshift button/arrow, and then select neutral. If HIGH splitter gauge = 55 to 65 PSI and if LOW splitter gauge = 0 PSI then repair the mechanical splitter system by removing the splitter cylinder cover and inspect the splitter cylinder.

Note: Five minutes is allowed for checking the air pressure after shifting the transmission to neutral.

After T/S of fault code if the technician determines the need to disassemble, try shop air to the cylinder housing port manually before disassembly, listening to determine if the piston moves in and out. Once the need to visually inspect the splitter cylinder is determined the tech may replace the o-rings and re-lube the cylinder walls with the silicone lubricant provided in the kit.

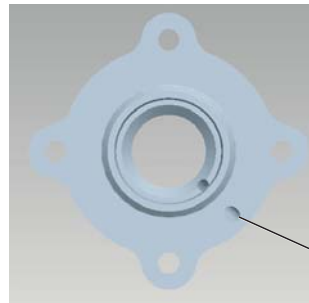

Feed air manually to this port, listen for piston to move in and out.

Recommended Software Update

Update software to the latest available version in ServiceRanger for all in-warranty transmissions.

Note: Please confirm the ServiceRanger program has the latest version and database. Please follow <http://www.roadranger.com/rr/Customersupport/Support/ServiceRanger/index.htm> to update the ServiceRanger program. Confirm the use of an approved communication adapter and ensure that all satellite systems are disabled.

Pre-Authorized Warranty Repair Guideline RWRG0051

Warranty Parts

- K-2803

Warranty Labor

- When diagnosing, the splitter complaint or software update will pay OEM SRT diagnostic time.
- When repair requires the replacement of the K-3510 the repair pays OEM SRT for splitter overhaul.

Warranty Coding

ATA Code: NA

Failed Part #: K-2803

Complaint Code: Splitter Shift - Slow (55)

Failure Code: Splitter Shifts (AG)

Responsibility Code: Vendor part (418)

Warranty Claim Filing

Reference warranty coverage. File pre-authorized warranty claim through appropriate OEM or through Direct Pay. Reference guideline number RWRG0051 in warranty claim text.

Note: Repairs that exceed parts and labor parameters cannot be pre-authorized.

Filing through Direct Pay

Click here for Direct Pay submission guidelines and claim forms:



**Submission Guidelines
and Claim Forms**

Parts Disposition

Parts can be scrapped.

Warranty Disclaimer

If the failure is not the result of an accident, damage, negligence, abuse or misuse, improper installation or maintenance or any other conditions described in the Limits and Exclusions section of Warranty Manual TCWY0600, then Roadranger will treat the condition as covered under its warranty. However, this conclusion does not necessarily mean that a defect in fact exists. In all cases, Roadranger shall make the final determination and interpretation as to the warrantability of the Product.

Pre-Authorized Warranty Repair Guideline RWRG0056

RWRG0056 - Range Shift Complaints - Fault Code 41

Symptom(s)

- A fault code 41 with a complaint of transmission not range shifting.

Cause

Range cylinder walls may become dry or contamination builds up in the cylinder which may cause the piston to move slowly or not at all.

Background

In the early stages there will be evidence of missed range shifts causing the driver to have only high or low gears. If the condition exists long enough there may be signs of damage to o-rings or the range solenoid valve. Any evidence of corrosion in the range cylinder will result in claim denial.

Repair Guideline

Perform the trouble shooting steps per the appropriate guide and check for correct air pressures.

STEP A

1. Key off
2. Install a 0-100 PSI air pressure gauge in the regulated test port of the air filer/regulator.
3. Start engine and allow air pressure to build to governor cut-off.
4. Monitor vehicle air pressure gauge on the dash and if vehicle maintains air pressure go to Step B.

STEP B

1. If air pressure is 75 to 85 psi (LAS/VAS models) or 55 to 65 psi (all other models) go to C.

STEP C

1. Key off
2. Install (2) 0-100 PSI air pressure gauges in the range cover diagnostic ports.
3. Start vehicle and allow air pressure to build to governor cut-off.

4. Turn off engine but leave the key in the ON position.
5. With Shift Control, select reverse, and then select neutral. If LOW range gauge = 75 to 85 psi (LAS/VAS) or 55 to 65 psi (all other) and if HIGH range gauge = 0 PSI go to Step D.

Note: Pressure change should be immediately reflected on the gauge.

STEP D

1. Key on
2. With Shift Control, select the highest reverse gear available by press the upshift button/arrow, and then select neutral. If HIGH range gauge = 75 to 85 psi (LAS/VAS) or 55 to 65 psi (all other) and if LOW range gauge = 0 PSI then repair the mechanical range system by removing the range cylinder cover and inspect the range cylinder.

Note: Pressure change should be immediately reflected on the gauge.

After troubleshooting the fault code, if the technician determines the need to disassemble, try shop air to the cylinder housing port manually before disassembly, listening to determine if the piston moves in and out. Once the need to visually inspect the range cylinder is determined the tech may replace the o-rings and re-lube the cylinder walls with the silicone lubricant provided in the kit.

Recommended Software Update

Update software to the latest available version in ServiceRanger for all in-warranty transmissions.

Note: Please confirm the ServiceRanger program has the latest version and database. Please follow <http://www.roadranger.com/rr/Customersupport/Support/ServiceRanger/index.htm> to update the ServiceRanger program. Confirm the use of an approved communication adapter and ensure that all satellite systems are disabled.

Warranty Parts

- K-3484

Pre-Authorized Warranty Repair Guideline RWRG0056

Warranty Labor

Eaton will pay OEM SRT diagnostic time when diagnosing the range shift complaint.

When repair requires the replacement of the K-3484 the repair pays OEM SRT for range cylinder overhaul and/or software update.

Warranty Coding

Failed Part #: K-3484

Complaint Code: Range Shift - Slow (34)

Failure Code: Range Shifts (AF)

Responsibility Code: Vendor part (418)

Warranty Claim Filing

Reference warranty coverage. File pre-authorized warranty claim through appropriate OEM or through Direct Pay. Reference guideline number RWRG0056 in warranty claim text.

Note: Repairs that exceed parts and labor parameters cannot be pre-authorized.

Filing through Direct Pay

Click here for Direct Pay submission guidelines and claim forms:



**Submission Guidelines
and Claim Forms**

Parts Disposition

Parts can be scrapped.

Warranty Disclaimer

If the failure is not the result of an accident, damage, negligence, abuse or misuse, improper installation or maintenance or any other conditions described in the Limits and Exclusions section of Warranty Manual TCWY0600, then Roadranger will treat the condition as covered under its warranty. However, this conclusion does not necessarily mean that a defect in fact exists. In all cases, Roadranger shall make the final determination and interpretation as to the warrantability of the Product.

Pre-Authorized Warranty Repair Guideline RWRG0063

RWRG0063 - Range Shift Complaint - Fault Code 43

Symptom(s)

A Fault Code 43 with recent time stamps and/or high number of occurrences with one or more of the following symptoms.

- Transmission is unable to complete a shift across the range.
- Transmission range is either stuck in HI or LO.
- Transmission cannot complete engagement into HI or LO.

If Fault Code 41 is also present, refer to Pre-Authorized Range Shift Complaints Fault Code 41 - Repair Guideline RWRG0056 available at www.roadranger.com.

Causes

This fault code can be caused by failure of short to battery, short to ground, or open circuit is detected in a Range Solenoid Valve or Transmission Harness.

Repair Guideline

When troubleshooting an inactive code see “Product Diagnostic Mode (PDM)” in the appropriate troubleshooting manual.

- UltraShift PLUS Troubleshooting (TRTS0940)
- Fuller Advantage Troubleshooting (TRTS0980)

Step A

Retrieve and document all transmission fault code information. Claim can be denied without this required information.

Step B

1. Key off and allow 2-3 minutes for the TECU to perform a complete power-down sequence.
2. Disconnect the 38-way Transmission Harness connector from the TECU and inspect connector body for damage and bent, spread, corroded or loose terminals.
3. Measure resistance between the Transmission Harness 38-way connector pins:
 - 28 and 6
 - 34 and 6

Note: Observe polarity on Volt/Ohm Meter.

If both resistances are within range of 9 to 16 ohms, go to Step C.

If resistance is outside of range, go to Step D.

Step C

1. Measure resistance between the following Transmission Harness connector and ground.
 - Measure resistance between the Transmission Harness 38-way connector pin 6 and ground.

If resistance is more than 10K ohms or open circuit [OL], replace Transmission Harness and Range Valve.

Step D

1. Disconnect the Transmission Harness from Range Valve.
2. Measure resistance between Range Valve pins:
 - A and C
 - B and C

If resistance is 9 to 16 ohms, replace Transmission Harness.

If resistance is outside of range, replace Range Valve.

Recommended Software Update:

Update software to the latest available version in ServiceRanger for all in-warranty transmissions.

Note: Please confirm the ServiceRanger program has the latest version and database. Please follow <http://www.roadranger.com/rr/Customersupport/Support/ServiceRanger/index.htm> to update the ServiceRanger program. Confirm the use of an approved communication adapter and ensure that all satellite systems are disabled.

Warranty Parts

- Range Valve (all models): K-3682
- UltraShift PLUS Transmission Harness options
 - VMS/VCS with Gen 1 ECA: K-3983
 - VMS/VCS with Gen 2 ECA: K-4257
 - MHP/MXP/VXP/VHP/LSE with Gen 1 ECA: K-3984
 - MHP/MXP/VXP/VHP/LSE with Gen 2 ECA: K-4256
 - LAS/VAS with Gen 1 ECA: K-3985
 - LAS/VAS with Gen 2 ECA: K-4255
- Fuller Advantage Transmission Harness options
 - EC3/EP3/EA3/EN3 with Gen 1 ECA: K-4214
 - EC3/EP3/EA3/EN3 with Gen 2 ECA: K-4295

Pre-Authorized Warranty Repair Guideline RWRG0063

Warranty Labor

When diagnosing the range shift complaint Eaton will pay OEM SRT diagnostic time.

When repair requires the replacement of the range valve and/or transmission harness, the repair pays OEM SRT for range valve replacement and/or Transmission Harness and/or software update.

Warranty Coding

- ATA Code: NA
- Failed Part #: Use Correct PN
- Complaint Code: Range Shift - Slow (34)
- Failure Code: Range Shifts (AF)
- Responsibility Code: RTW COMMITMENT (601)

Warranty Claim Filing

Reference warranty coverage. File pre-authorized warranty claim through appropriate OEM or through Direct Pay. Reference guideline number RWRG0063 in warranty claim text.

Note: Repairs that exceed parts and labor parameters cannot be pre-authorized.

Filing through Direct Pay

Click here for Direct Pay submission guidelines and claim forms:



Parts Disposition

Parts return required.

Warranty Disclaimer

If the failure is not the result of an accident, damage, negligence, abuse or misuse, improper installation or maintenance or any other conditions described in the Limits and Exclusions section of Warranty Manual TCWY0600, then Roadranger will treat the condition as covered under its warranty. However, this conclusion does not necessarily mean that a defect in fact exists. In all cases, Roadranger shall make the final determination and interpretation as to the warrantability of the Product.

Roadranger Warranty Repair Guideline RWRG0069

RWRG0069 - Fault Code 64 on Generation 1 Electronic Clutch Actuator (ECA)

Overview

The UltraShift PLUS transmission is equipped with an Electronic Clutch Actuator (ECA) that controls the position of the clutch assembly. Power and ground to the ECA are OEM-supplied through a 3-Way Connector directly connected to the vehicle batteries. The ECA is connected to the Transmission Electronic Control Unit (TECU) by an 8-Way Connector that is part of the transmission harness. The ECA communicates with the TECU over the High Integrity Link (HIL) to change position, show faults or include other operation information.

Note: It has been determined that performing an electrical pre-test is not needed.

Symptom(s)

- “F” flashes in gear display.
- Service light flashes (if equipped).
- If the fault occurs at power up, engine cranks and starts, but TECU will not engage a gear.
- If the fault occurs while driving, ECA maintains current clutch position or moves to the last position commanded by the TECU. Transmission may continue to shift until vehicle is stopped.

Warranty Coverage

- This Warranty Repair Guideline repair DOES NOT apply if a Generation (Gen) 2 ECA is installed on the truck (see Step A and the Component ID for proper ECA Identification.). If the truck is equipped with a Gen 2 ECA please follow normal troubleshooting procedure and call 800-826-4357 for additional assistance.
- This Warranty Repair Guideline repair DOES NOT apply if the Generation (Gen) 1 ECA has been replaced within the last 90 days on the truck. If the Gen 1 ECA has been replaced within the last 90 days follow normal troubleshooting procedure and call 800-826-4357 for additional assistance.
- The warranty coverage varies depending on vehicle vocation and transmission model type. Warranty coverage is the same as that of its respective transmission coverage including extended warranty.

Possible Causes

FMI 12:

- ECA Power Harness
- ECA

FMI 7:

- ECA Power Harness
- Mechanical Clutch System
- ECA

Roadranger Warranty Repair Guideline RWRG0069

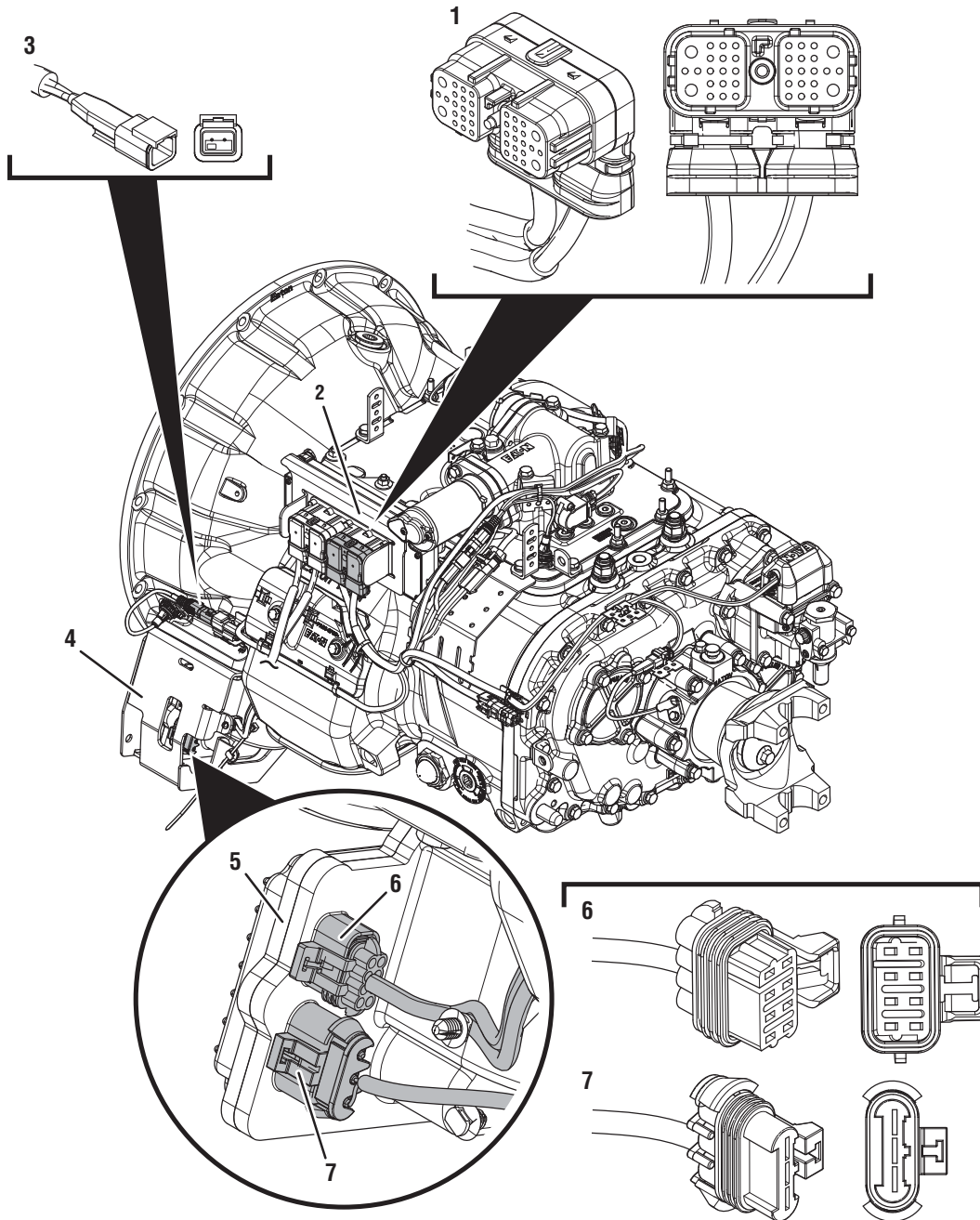

- 1. 38-Way Vehicle Harness Connector
- 2. Transmission Electronic Control Unit (TECU)
- 3. ECA Shield
- 4. Electronic Clutch Actuator (ECA)
- 5. 8-Way ECA Connector
- 6. 3-Way ECA Power Supply Connector

Roadranger Warranty Repair Guideline RWRG0069

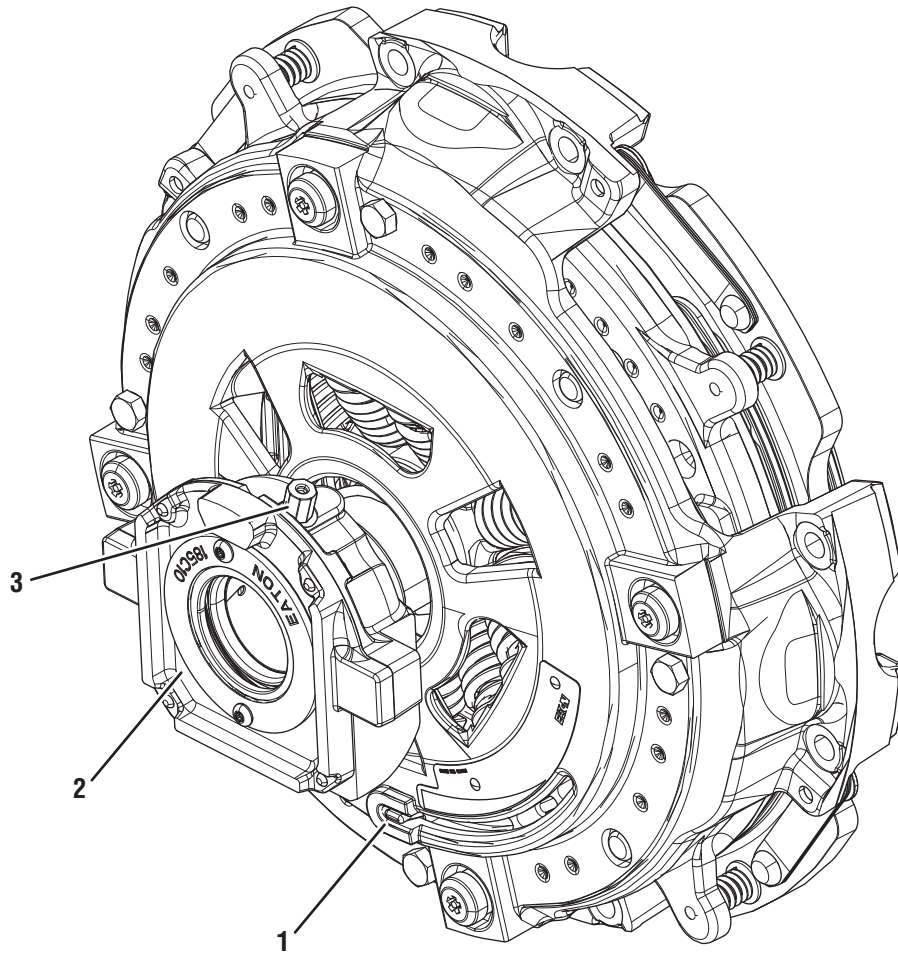

Eaton ECA Clutch

1. Clutch Wear Tab

2. Release Bearing

3. Release Bearing Grease Zerk

Fault Code 64 Troubleshooting and Repair Guidelines

A

Purpose: Identify ECA installed on transmission.

1. Inspect ECA OEM Power Supply Connector, reference image below.

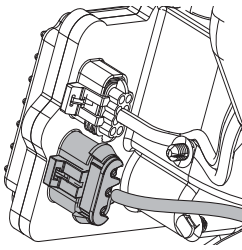

Gen1 ECA

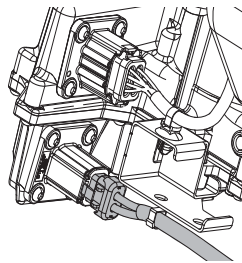

Gen2 ECA

- If equipped with a **Gen1 ECA**, Go to Step B.
- If equipped with a Gen2 ECA, troubleshoot active codes, refer to the appropriate Troubleshooting Guide on Roadranger.com. This Warranty Pre-Authorization **DOES NOT** apply to a Gen 2 ECA part.

B

Purpose: Check for Active or Inactive fault codes.

1. Record the transmission fault codes, FMIs, occurrences, and timestamps from the Service Activity Report created during the Diagnostic Procedure.
 - If Fault Code 64 is Inactive and there are other Active fault codes, troubleshoot active codes, refer to the appropriate Troubleshooting Guide on Roadranger.com. This Warranty Repair Guideline **DOES NOT** apply when other active codes are present and code 64 is inactive.
 - If Fault Codes 15, 16 or 19 is Active, troubleshoot active codes, refer to the appropriate Troubleshooting Guide on Roadranger.com. This Warranty Repair Guideline **DOES NOT** apply when these codes are present.
 - If Fault Code 64 is active or inactive and the scenarios above do not apply, **go to Step C.**

C

Purpose: Check fault code type.

1. Determine which FMI set for Fault Code 64, as noted in Step B.
 - If FMI 12 sets and no other fault codes are active, replace the ECA. Go to Step V.
 - If FMI 7 set, remove ECA and Inspect for clutch damage or failure. If no issues found, replace ECA. Go to Step V.

V

Purpose: Verify repair.

1. Key off.
2. Reconnect all connectors and verify that all components are properly installed.
3. Key on.
4. Clear fault codes using ServiceRanger.
5. Drive vehicle and attempt to reset the code or duplicate the previous complaint.
6. Check for fault codes using ServiceRanger.
 - If no codes set and the vehicle operates properly, test complete.
 - If Fault Code 64 sets active during the test drive, Perform 1 clutch adjustment and reattempt.
 - If a fault code other than 64 sets, troubleshoot using appropriate troubleshooting manual.

Roadranger Warranty Repair Guideline RWRG0069

Warranty Parts

- K-4252: Gen 2 ECA, includes adapter harness to OEM power supply and shield.

Warranty Labor

- ECA R&R SRT – 0.7 hrs
- Pull Codes and Send Service Activity Report – 0.3 hr
- Software, if required – 0.5 hr
- Road test repair confirmation –0.5 hrs

Warranty Coding

- Part: 4306651 (Gen 1 ECA)
- Complaint: FAIL LIGHT FLASHING
- Failure: ROOT CAUSE NOT DETERMINED

Warranty Claim Filing

File Pre-Authorized warranty claim through appropriate OEM or through Direct Pay. Document in Warranty Claim text/notes:

- RWRG0069
- OEM Warranty Coverage
- Software Revision from and to

Filing through Direct Pay

Click here for Direct Pay submission guidelines and claim forms:



Parts Disposition

Return Parts per OEM or Direct Pay guidelines.

Warranty Disclaimer

If the failure is not the result of an accident, damage, negligence, abuse or misuse, improper installation or maintenance or any other conditions described in the Limits and Exclusions section of the Eaton Warranty Manual TCWY0600, then Eaton will treat the condition as covered under its warranty. However, this conclusion does not necessarily mean that a defect in fact exists. In all cases, Eaton shall make the final determination and interpretation as to the warrantability of the product.

Pre-Authorized Warranty Repair Guideline RWRG0070

RWRG0070 - X-Y Shifter Leaks

Symptom(s)

- Oil weep or leak at the X-Y shifter

Warranty Coverage

The warranty coverage varies depending on vehicle vocation and transmission model type. Warranty coverage is the same as that of its respective transmission coverage including extended warranty.

Cause

Gasket not properly sealing mating surfaces, allowing oil weep or leak at the X-Y shifter position sensors and or the X-Y shifter to shift bar housing.

Repair Guideline

Remove the X-Y shifter and replace all contents within the K-4287: Position Sensor Gasket Kit.

- (1) 4305452: X-Y Shifter Hsg Gasket
- (2) 4308793: Beaded Position Sensor Gasket
- (4) X-8-261: Screw #10-24 X 1 ¼"
- (4) X-8-270: Screw #10-24 X 1 ½"

Note: Content quantities of parts included in the K-4287 will accommodate both X-Y position sensors and the X-Y to shift bar housing gasket surfaces.

Warranty Parts

- K-4287: Position Sensor Gasket Kit

Warranty Labor

- X-Y shifter R&R per OEM SRT
- R&R 2 X-Y shifter position sensors - 0.5 hrs (total)

Warranty Coding

- Part: 691550 (position sensor leak)
- Complaint: OIL LEAK
- Failure: LEAKING

Warranty Claim Filing

File pre-authorized warranty claim through appropriate OEM or through Direct Pay. Reference guideline number RWRG0070 in warranty claim text.

- RWRG0070
- OEM Warranty Coverage

Note: Repairs that exceed parts and labor parameters cannot be pre-authorized.

Filling Through Direct Pay

Click here for Direct Pay submission guidelines and claim forms:



**Submission Guidelines
and Claim Forms**

Parts Disposition

Parts can be scrapped.

Warranty Disclaimer

If the failure is not the result of an accident, damage, negligence, abuse or misuse, improper installation or maintenance or any other conditions described in the Limits and Exclusions section of the Eaton Warranty Manual TCWY0600, then Eaton will treat the condition as covered under its warranty. However, this conclusion does not necessarily mean that a defect in fact exists. In all cases, Eaton shall make the final determination and interpretation as to the warrantability of the product.

RWRG0071 - Transmission Electronic Control Unit Fault Code 11 FMI 12 Pre-Authorization

Overview

The UltraShift *PLUS* transmission is equipped with a Transmission Electronic Control Unit (TECU). The TECU performs a variety of functions including receiving inputs from sensors, sending outputs to control devices, operating X-Y Shifter motors and actuators and making shift decisions. Fault Code 11 indicates an internal failure of the TECU.

Note: It has been determined that performing an electrical pre-test is not needed.

Symptom(s)

- “F” flashes in gear display.
- Service light flashes (if equipped).
- Engine may not crank.
- Transmission may not attempt to shift.
- Transmission may not confirm neutral.
- Engine may have to be shut down with transmission still in gear.

Component Identification

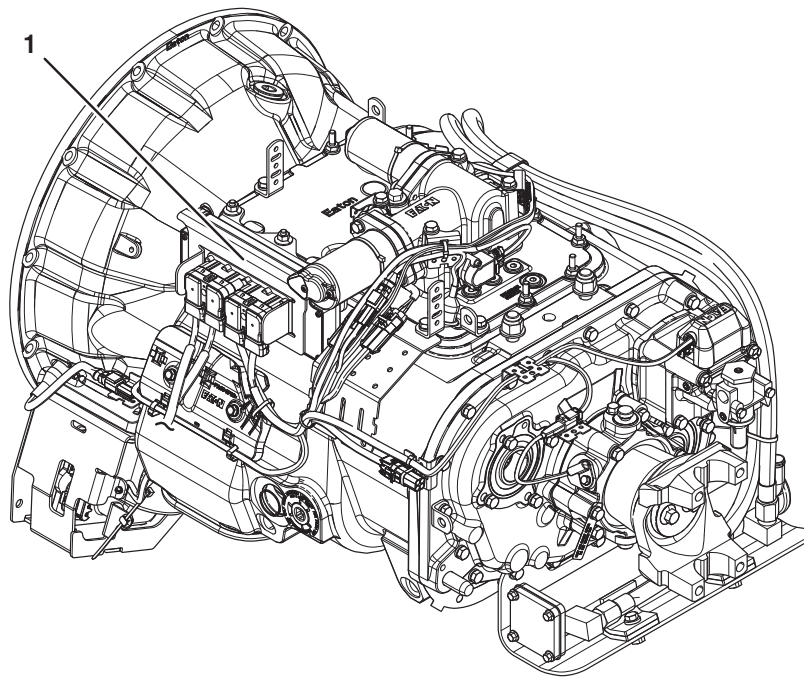

1. Transmission Electronic Control Unit (TECU)

Warranty Coverage

This Warranty Repair Guideline repair DOES NOT apply if the Fault Code is Inactive and there are other Active Faults in the Eaton/OEM System. If there are other Active Faults, please follow normal troubleshooting procedure using the correct troubleshooting manual per transmission model.

This Pre-Authorization DOES NOT apply if the failed part has been replaced within the last 90 days on the truck.

The warranty coverage varies depending on vehicle vocation and transmission model type. Warranty coverage is the same as that of its respective transmission coverage including extended warranty.

Possible Causes

- TECU

Fault Code 11 Troubleshooting

A

Purpose: Check for Active Fault Code 11 FMI 12, create and send in Service Activity Report (SAR)

1. Record the transmission fault codes, FMIs, occurrences, and timestamps from the Service Activity Report.
 - If Fault Code 11 is the **ONLY CODE** Active and present in SAR, replace TECU. Go to **Step V.**

V

Purpose: Verify repair.

1. Key off.
2. Reconnect all connectors and verify that all components are properly installed.
3. Key on with engine off.
4. Clear fault codes using ServiceRanger.
5. Drive vehicle and attempt to reset the code or duplicate the previous complaint.
6. Check for fault codes using ServiceRanger.
 - If no fault codes set Active and vehicle operates properly, test complete.
 - If Fault Code 11 sets Active during the test drive, utilize roadranger.com for further troubleshooting options.
 - If a fault code other than 11 sets Active, troubleshoot using appropriate troubleshooting manual.

Warranty Labor

- TECU R&R per OEM SRT
- Grade Sensor Calibration SRT
- .3 HR TECU Configuration Update
- .5 HR Road Test

Warranty Coding

- Complaint: ENGAGEMENT - NO GEAR FRM NEUTRAL
- Failure: ROOT CAUSE NOT DETERMINED

Warranty Claim Filing

File pre-authorized warranty claim through appropriate OEM or through Direct Pay.

- RWRG0071
- OEM Warranty Coverage

Filing through Direct Pay

Click here for Direct Pay submission guidelines and claim forms:



Submission Guidelines and Claim Forms

Parts Disposition

Return parts per OEM or Direct Pay Guidelines.

Warranty Disclaimer

If the failure is not the result of an accident, damage, negligence, abuse or misuse, improper installation or maintenance or any other conditions described in the Limits and Exclusions section of the Eaton Warranty Manual TCWY0600, then Eaton will treat the condition as covered under its warranty. However, this conclusion does not necessarily mean that a defect in fact exists. In all cases, Eaton shall make the final determination and interpretation as to the warrantability of the product.

Warranty Parts

- TECU (part numbers vary)

RWRG0072 - Fault Code 46 Pre-Authorization

Overview

The LSE, MHP, MXP, VCS, VHP, VMS and VXP series transmissions are equipped with a 2-speed splitter system in the auxiliary case. The splitter system uses a reduction gear to increase the total number of gear ratios available to the transmission. It also reduces the gear ratio step-sizes between shifts by using the main case gearing once in auxiliary low split and then again in auxiliary high split. The system can use the reduction gear to allow the transmission to operate at very low speeds (or creep) applications.

The splitter system is equipped with a Splitter Solenoid Valve. The Splitter Solenoid Valve is an electric-over-air solenoid that is controlled by the Transmission Electronic Control Unit (TECU), replacing the Shift Knob-Splitter Button system found on Eaton Fuller manual transmissions.

During operation, the solenoid directs air pressure to either port in the Splitter Cover based on the need to activate the auxiliary low split or high split gearing. The applied air pressure directs the fore-and-aft movement of the Splitter Piston within the Splitter Cylinder, facilitating the mechanical engagement of either low or high split position. Fault Code 46 indicates an electrical fault within the Splitter Solenoid Valve circuit.

Note: it has been determined that performing an electrical pre-test is not needed.

Symptom(s)

- “F” flashes in gear display.
- Service light flashes (if equipped).
- Engine cranks and starts.
- High side coil failure.
 - If the failure occurs in high split, the transmission shifts through all high-split gears and shifts to low split when vehicle speed is appropriate; however, the transmission is then restricted to shifting in all low split gears only.
- Low side coil failure.
 - If the failure occurs in high split, the transmission shifts through all high split gears but will not shift into low split.

Warranty Coverage

This Warranty Repair Guideline repair DOES NOT apply if the Fault Code is Inactive and there are other Active Faults in the Eaton/OEM System. If there are other Active Faults, please follow normal troubleshooting procedure using the correct troubleshooting manual per transmission model.

This Pre-Authorization DOES NOT apply if the failed part has been replaced within the last 90 days on the truck.

The warranty coverage varies depending on vehicle vocation and transmission model type. Warranty coverage is the same as that of its respective transmission coverage including extended warranty.

Possible Causes

Note: if an FMI other than shown is present pre-authorization does not apply

FMI 4

- Transmission Harness
- Electronic Solenoid Valve Kit

FMI 5

- Transmission Harness
- Electronic Solenoid Valve Kit

Pre-Authorized Warranty Repair Guideline RWRG0072

Component Identification

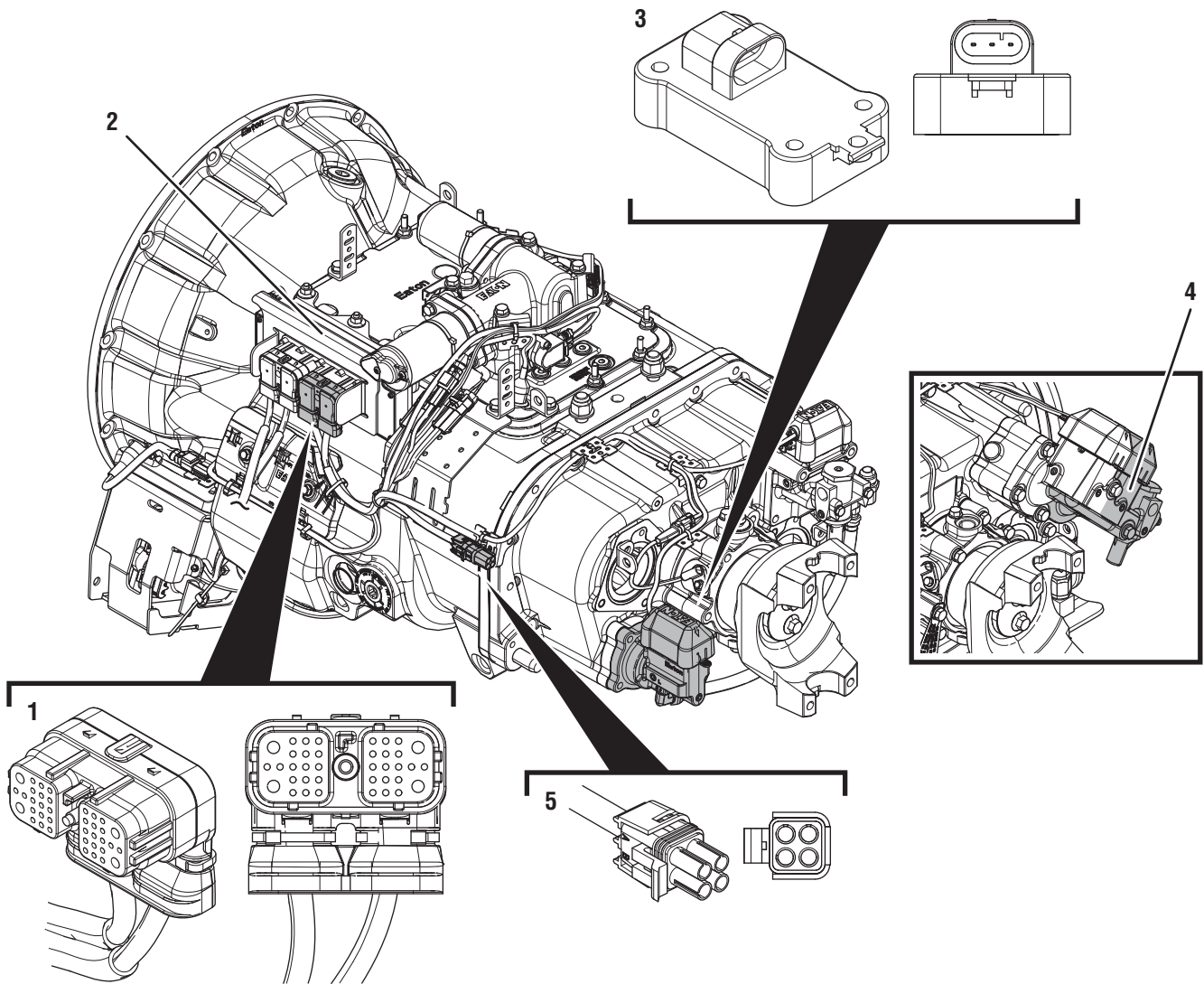

1. 38-Way Transmission Harness Connector
2. Transmission Electronic Control Unit (TECU)
3. Splitter Solenoid Valve (MHP / VHP / MXP / LSE / VXP)
4. Splitter Solenoid Valve (VCS / VMS)
5. 4-Way Diagnostic Connector

Pre-Authorized Warranty Repair Guideline RWRG0072

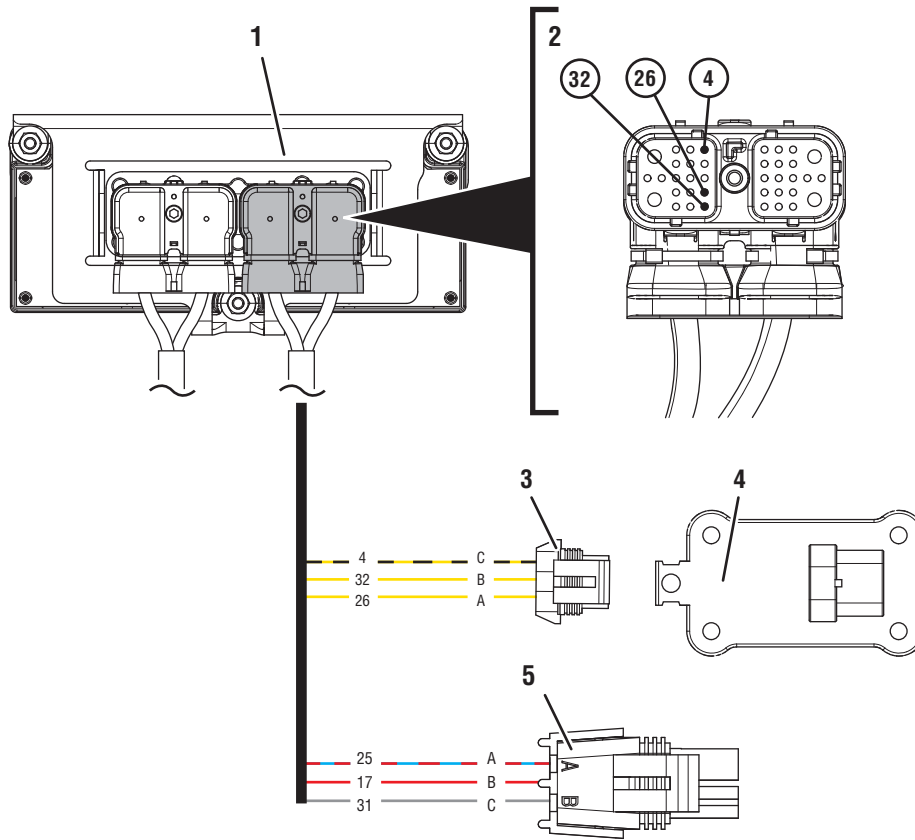

- 1. Transmission Electronic Control Unit (TECU)
- 2. 38-Way Transmission Harness Connector
- 3. 3-Way Splitter Solenoid Valve Connector
- 4. 3-Way Splitter Solenoid Valve
- 5. 4-Way Diagnostic Connector

■ Battery Voltage	■ Switched Battery from TECU	■ Ground	■ Communication	■ Signal
■ Ignition Voltage	■ Switched 5V from TECU	■ Switched Ground	■ Relay/Solenoid Driver	

Fault Code 46 Troubleshooting

A

Purpose: Check for Active or Inactive fault codes.

1. Create and send Service Activity Report using ServiceRanger.
 - If Fault Code 46 is Active or Inactive, replace Transmission Harness and Electronic Solenoid Valve Kit. Go to **Step V.**

V

Purpose: Verify repair.

1. Key off.
2. Reconnect all connectors and verify that all components are properly installed.
3. Key on with engine off.
4. Clear fault codes using ServiceRanger.
5. Drive vehicle and attempt to reset the code or duplicate the previous complaint.
6. Check for fault codes using ServiceRanger.
 - If no fault codes set Active and vehicle operates properly, test complete.
 - If Fault Code 46 sets Active during the test drive, utilize roadranger.com for further troubleshooting options.
 - If a fault code other than 46 sets, troubleshoot using appropriate troubleshooting manual.

Warranty Parts

- K-3682: Electronic Solenoid Valve Kit
- P/N Varies: Transmission Harness

Warranty Labor

- Transmission Harness R&R SRT per OEM Guidelines
- Electronic Solenoid Valve Kit R&R SRT per OEM Guidelines
- Diagnostics - 0.3 hr
- Road test repair confirmation – 0.5 hrs

Warranty Coding

- Complaint: Fail Light Flashing
- Failure: Root Cause Not Determined

Warranty Claim Filing

File pre-authorized warranty claim through appropriate OEM or through Direct Pay.

- RWRG0072
- OEM Warranty Coverage

Filing through Direct Pay

Click here for Direct Pay submission guidelines and claim forms:



**Submission Guidelines
and Claim Forms**

Parts Disposition

Return Parts per OEM or Direct Pay guidelines.

Warranty Disclaimer

If the failure is not the result of an accident, damage, negligence, abuse or misuse, improper installation or maintenance or any other conditions described in the Limits and Exclusions section of the Eaton Warranty Manual TCWY0600, then Eaton will treat the condition as covered under its warranty. However, this conclusion does not necessarily mean that a defect in fact exists. In all cases, Eaton shall make the final determination and interpretation as to the warrantability of the product.

RWRG0073 - Fault Code 51 Rail Position Sensor Pre-Authorization

Overview

The X-Y Shifter is equipped with a Rail Position Sensor. The X-Y Rail Position Sensor reports lateral movement of the Shift Finger to the Transmission Electronic Control Unit (TECU) as a voltage signal. The X-Y Rail Position Sensor is connected to the TECU via the Transmission Harness.

The TECU performs continuous diagnostics on the circuit to detect a shorted circuit, open circuit or incorrect position reading. Fault Code 51 is set when the TECU has detected either an electrical failure of the X-Y Rail Position Sensor circuit or a mechanical failure within the X-Y Shifter.

Note: it has been determined that performing an electrical pre-test is not needed.

Symptom(s)

- “F” flashes in gear display.
- Service light flashes (if equipped).
- Transmission remains in current gear.
- Until the fault becomes Inactive, driver may have to shut off engine with transmission in gear.

Warranty Coverage

This Warranty Repair Guideline repair DOES NOT apply if the Fault Code is Inactive and there are other Active Faults in the Eaton/OEM System. If there are other Active Faults, please follow normal troubleshooting procedure using the correct troubleshooting manual per transmission model.

This Pre-Authorization DOES NOT apply if the failed part has been replaced within the last 90 days on the truck.

The warranty coverage varies depending on vehicle vocation and transmission model type. Warranty coverage is the same as that of its respective transmission coverage including extended warranty.

Possible Causes

FMI 2, 10

- Transmission Harness
- X-Y Shifter

Pre-Authorized Warranty Repair Guideline RWRG0073

Component Identification

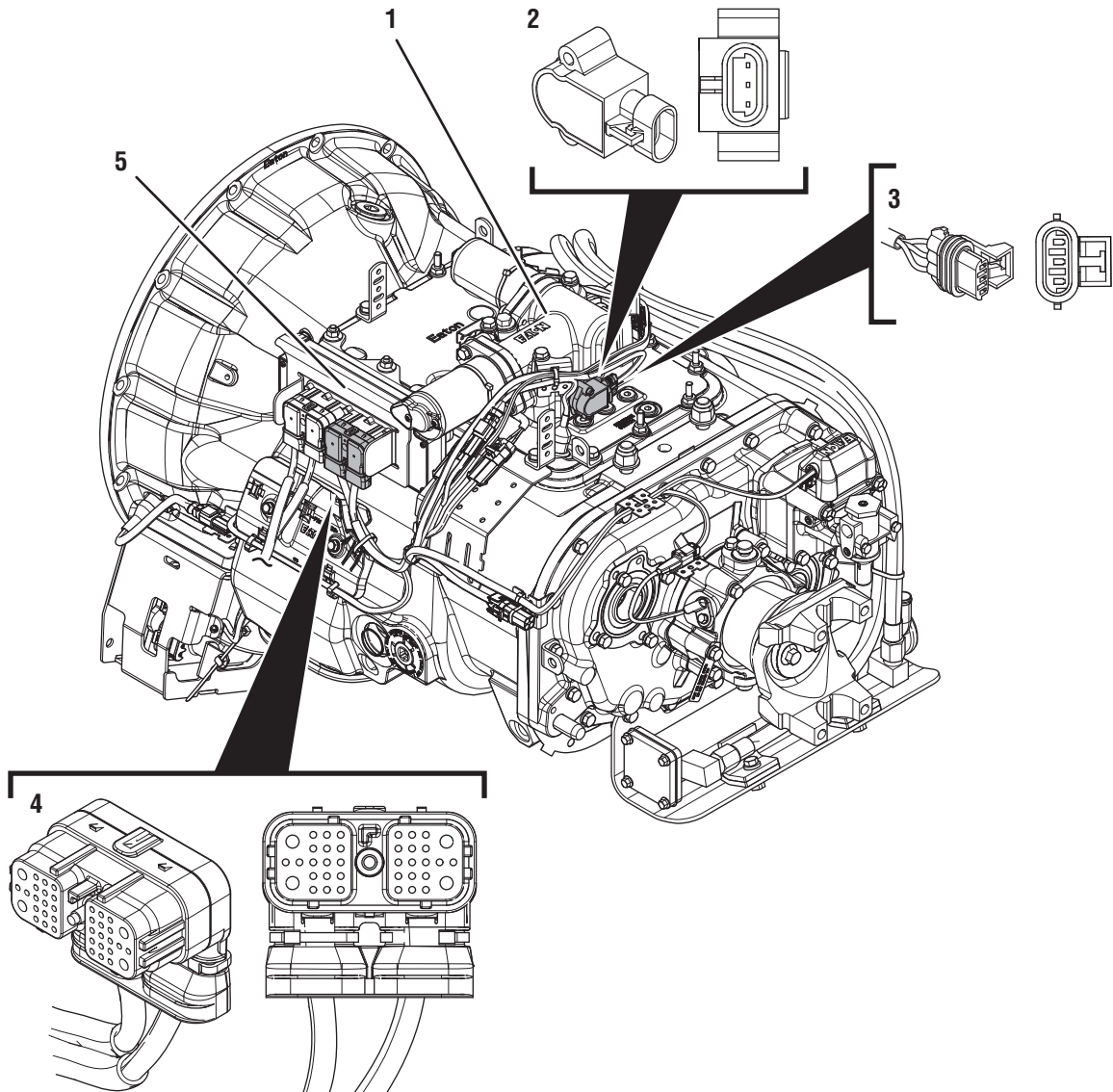

- 1. X-Y Shifter
- 2. 3-Way Rail Position Sensor
- 3. 3-Way Rail Position Sensor Connector
- 4. 38-Way Transmission Harness Connector
- 5. Transmission Electronic Control Unit (TECU)

Pre-Authorized Warranty Repair Guideline RWRG0073

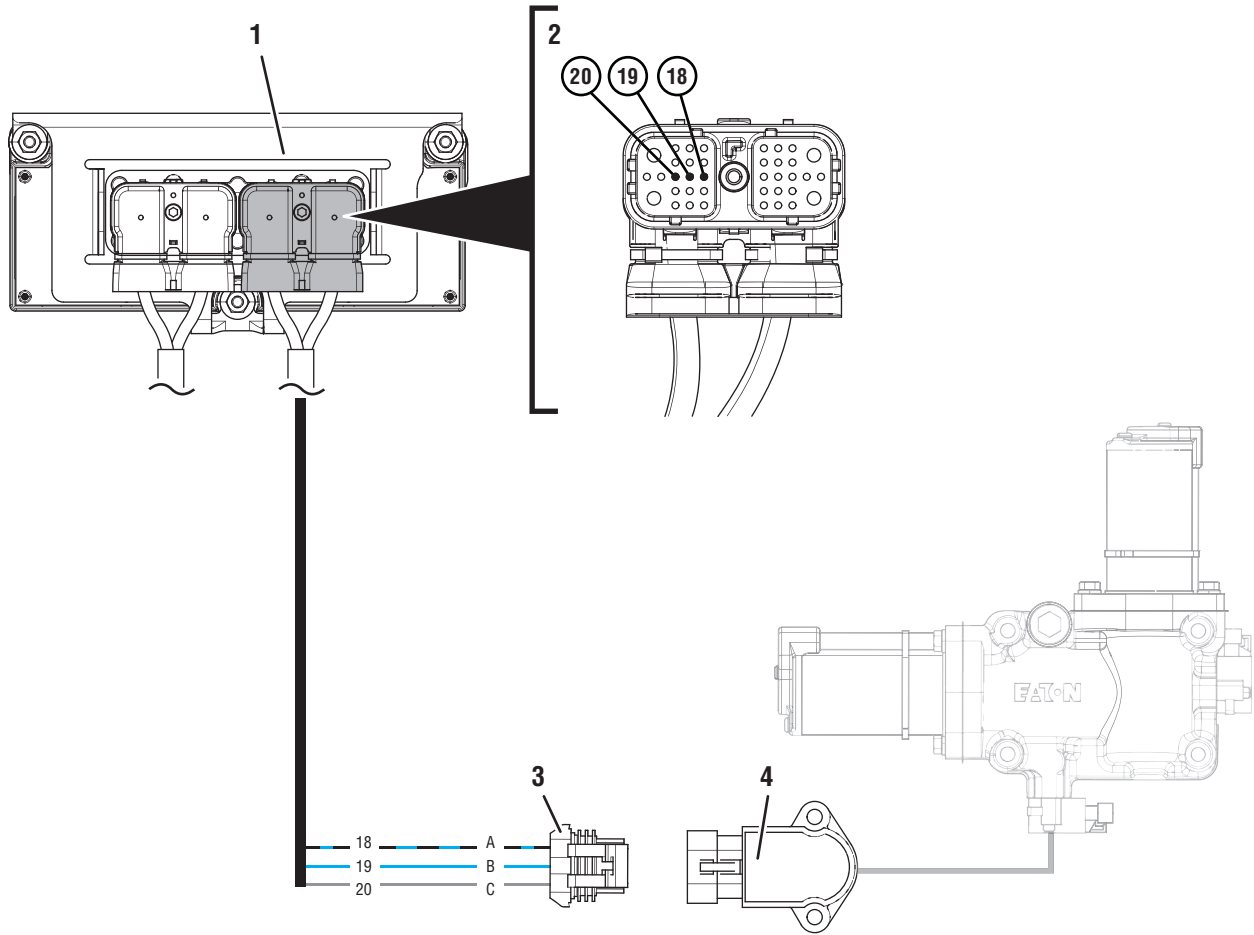

- 1. Transmission Electronic Control Unit (TECU)
- 2. 38-Way Transmission Harness Connector
- 3. 3-Way Rail Position Sensor Connector
- 4. 3-Way Rail Position Sensor

■ Battery Voltage	■ Switched Battery from TECU	■ Ground	■ Communication	■ Signal
■ Ignition Voltage	■ Switched 5V from TECU	■ Switched Ground	■ Relay/Solenoid Driver	

Fault Code 51 Troubleshooting

A

Purpose: Check for Active or Inactive fault codes.

1. Record the transmission fault codes, FMIs, occurrences, and timestamps from the Service Activity Report created during the Diagnostic Procedure.

Note: check history for **X-Y Shifter** replacement. If recent, replace harness

- If Fault Code 51 FMI 10 is Active, go to **Step C.**
 - If Fault Code 51 FMI 10 is Inactive, go to **Step B.**
 - If Fault Code 51 FMI 2 is Active or Inactive, go to **Step D.**
-

B

Purpose: Use Product Diagnostic (PD) Mode to locate intermittent failures.

1. Set parking brake and chock wheels.
2. Place transmission in PD Mode.

Note: Transmission does not enter PD Mode when Active fault codes exist.



3. Wiggle wiring and connections of the Transmission Harness between the Rail Position Sensor and the TECU.
4. Exit PD Mode by powering down.



IMPORTANT: Allow 2–3 minutes for the TECU to perform a complete power-down sequence before proceeding.

- If any fault codes set Active while wiggling the Transmission Harness, replace Transmission Harness. Go to **Step V.**
 - If no fault codes set Active while wiggling the Transmission Harness, go to **Step C.**
-

Pre-Authorized Warranty Repair Guideline RWRG0073

C *Purpose: Check for short to ground in Rail Position circuit.*

1. Key off.
2. Disconnect 38-Way Transmission Harness Connector from the TECU.
3. Inspect 38-Way Connector body for damage and bent, spread, corroded or loose terminals.
4. Measure resistance between 38-Way Transmission Harness Connector Pin 18 and ground. Record reading(s) in table.

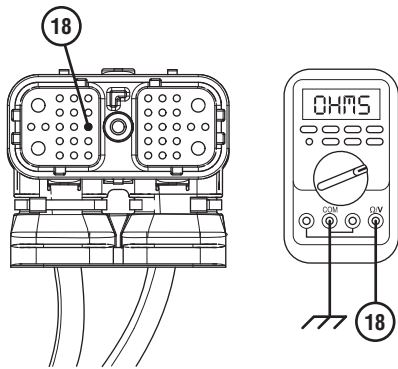

5. Compare reading(s) in table.
 - If connector is damaged, replace Transmission Harness. Go to **Step V.**
 - If readings are in range, go to **Step E.**
 - If readings are out of range, replace Transmission Harness. Go to **Step V.**

Pins	Range	Reading(s)
18 to Ground	Open Circuit (OL)	

D *Purpose: Verify the condition of the 38-Way Transmission Harness Connector.*

1. Key off.
2. Disconnect 38-Way Transmission Harness Connector from the TECU.
3. Verify the connector is free from contamination and corrosion; the terminals are not bent, spread or loose; and there is no damage to the connector body.
4. Inspect the TECU side of the 38-Way Transmission Harness Connector for contamination and corrosion; the terminals are not bent, spread or loose; and there is no damage to the connector body.
 - If no contamination or damage is found, go to **Step E.**
 - If contamination or damage is found, replace the Transmission Harness. Go to **Step V.**

Pre-Authorized Warranty Repair Guideline RWRG0073

E

Purpose: Verify the proper resistance of the Rail Position Sensor circuit.

1. Key off.
2. Measure resistance between 38-Way Transmission Harness Connector Pin 18 and Pin 19. Record reading(s) in table.

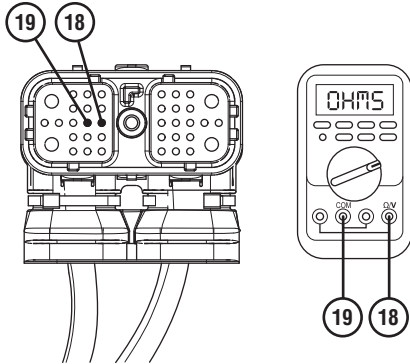

3. Measure resistance between 38-Way Transmission Harness Connector Pin 18 and Pin 20. Record reading(s) in table.

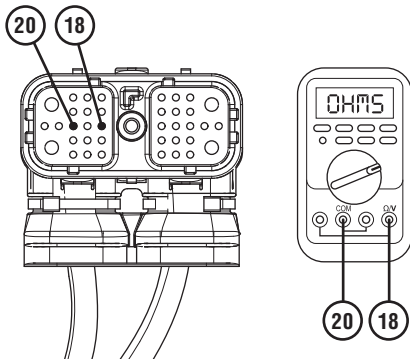

4. Compare reading(s) in table.
 - If all readings are in range, replace transmission harness.
 - If either reading is out of range, go to **Step F.**

Pins	Range	Reading(s)
18 to 19	150–200 ohms	
18 to 20	5.5k–6.5k ohms	

Pre-Authorized Warranty Repair Guideline RWRG0073

F

Purpose: Measure the resistance of the Rail Position Sensor.

1. Key off.
2. Disconnect 3-Way Transmission Harness Connector from 3-Way Rail Position Sensor.
3. Inspect 3-Way Connector body for damage and bent, spread, corroded or loose terminals.
4. Measure resistance between 3-Way Rail Position Sensor Body Pin A and Pin C. Record reading(s) in table.

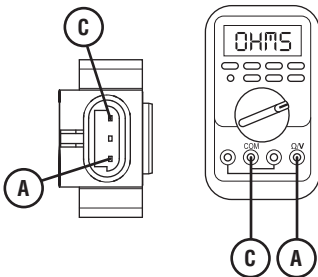

5. Measure resistance between 3-Way Rail Position Sensor Body Pin A and Pin B. Record reading(s) in table.

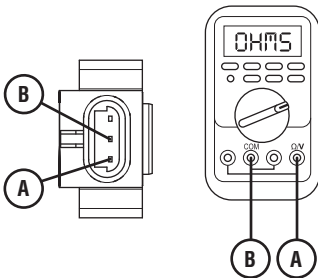

6. Compare reading(s) in table.

- If the connector is damaged, replace Transmission Harness. Go to **Step V.**
- If either reading is out of range, replace X-Y Shifter and Transmission Harness. Go to **Step V.**

Pins	Range	Reading(s)
A to B	150–200 ohms	
A to C	5.5k–6.5k ohms	

V

Purpose: Verify repair.

1. Key off.
2. Reconnect all connectors and verify that all components are properly installed.
3. Key on with engine off.
4. Clear fault codes using ServiceRanger.
5. Drive vehicle and attempt to reset the code or duplicate the previous complaint.
6. Check for fault codes using ServiceRanger.
 - If no fault codes set Active and the vehicle operates properly, test complete.
 - If Fault Code 51 sets Active during the test drive, utilize roadranger.com for further troubleshooting options.
 - If a fault code other than 51 sets Active, troubleshoot using appropriate troubleshooting manual.

Pre-Authorized Warranty Repair Guideline RWRG0073

Warranty Parts

- X-Y Shifter
- Transmission Harness

Warranty Labor

- Diagnostics - 0.5 hr
- Check Codes - 0.3 hr
- Software Update if not current version - 0.5 hr
- SRT X-Y Shifter R&R If Required in Troubleshooting
- SRT Transmission Harness R&R

Warranty Coding

- Failed Part #: Harness or XY Shifter Kit Number
- Complaint Code: STUCK IN GEAR
- Failure Code: ROOT CAUSE NOT DETERMINED

Warranty Claim Filing

File pre-authorized warranty claim through appropriate OEM or through Direct Pay.

- RWRG0073
- OEM Warranty Coverage
- Software Revision (from and to)

Note: Repairs that exceed parts and labor parameters cannot be pre-authorized.

Filing through Direct Pay

Click here for Direct Pay submission guidelines and claim forms:



**Submission Guidelines
and Claim Forms**

Parts Disposition

Return All Parts Per OEM or Direct Pay Guidelines

Warranty Disclaimer

If the failure is not the result of an accident, damage, negligence, abuse or misuse, improper installation or maintenance or any other conditions described in the Limits and Exclusions section of the Eaton Warranty Manual TCWY0600, then Eaton will treat the condition as covered under its warranty. However, this conclusion does not necessarily mean that a defect in fact exists. In all cases, Eaton shall make the final determination and interpretation as to the warrantability of the product.

RWRG0074 - Fault Code 52 Pre-Authorized Repair

Overview

The X-Y Shifter is equipped with a Gear Position Sensor. The X-Y Gear Position Sensor reports fore-and-aft movement of the Shift Finger to the Transmission Electronic Control Unit (TECU) as a voltage signal. The X-Y Gear Position Sensor is connected to the TECU via the Transmission Harness.

The TECU performs continuous diagnostics on the circuit to detect a shorted circuit, open circuit or incorrect position reading. Fault Code 52 is set when TECU has detected either an electrical failure of the X-Y Gear Position Sensor circuit or a mechanical failure within the X-Y Shifter.

Note: it has been determined that performing an electrical pre-test is not needed.

Symptom(s)

- “F” flashes in gear display.
- Service light flashes (if equipped).
- Transmission remains in current gear.
- Until the fault becomes Inactive, driver may have to shut off engine with transmission in gear.

Warranty Coverage

This Warranty Repair Guideline repair DOES NOT apply if the Fault Code is Inactive and there are other Active Faults in the Eaton/OEM System. If there are other Active Faults, please follow normal troubleshooting procedure using the correct troubleshooting manual per transmission model.

This Pre-Authorization DOES NOT apply if the failed part has been replaced within the last 90 days on the truck.

The warranty coverage varies depending on vehicle vocation and transmission model type. Warranty coverage is the same as that of its respective transmission coverage including extended warranty.

Possible Causes

2, 7

- Transmission Harness
- X-Y Shifter

Pre-Authorized Warranty Repair Guideline RWRG0074

Component Identification

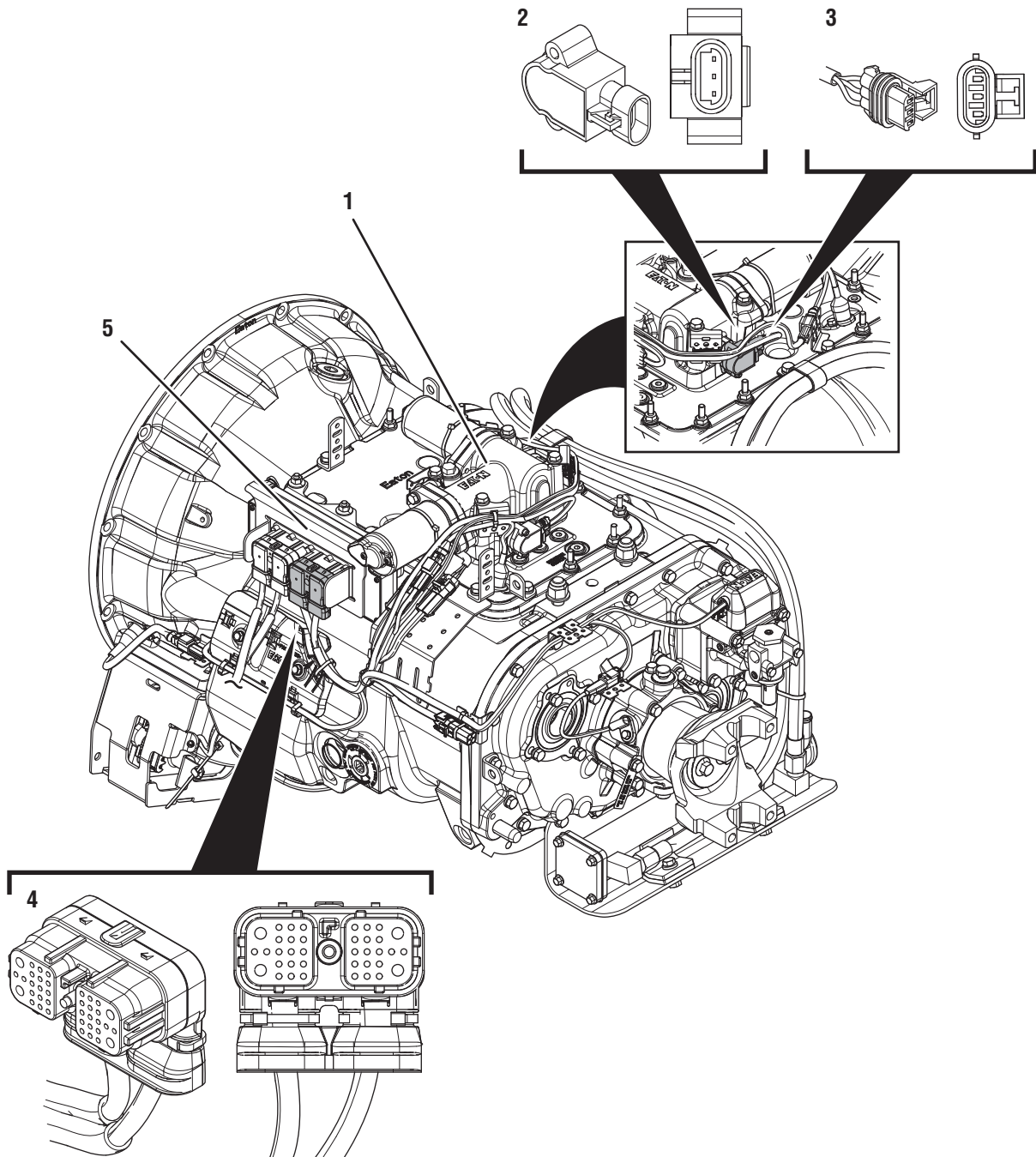

- 1. X-Y Shifter
- 2. 3-Way Gear Position Sensor
- 3. 3-Way Gear Position Sensor Connector
- 4. 38-Way Transmission Harness Connector
- 5. Transmission Electronic Control Unit (TECU)

Pre-Authorized Warranty Repair Guideline RWRG0074

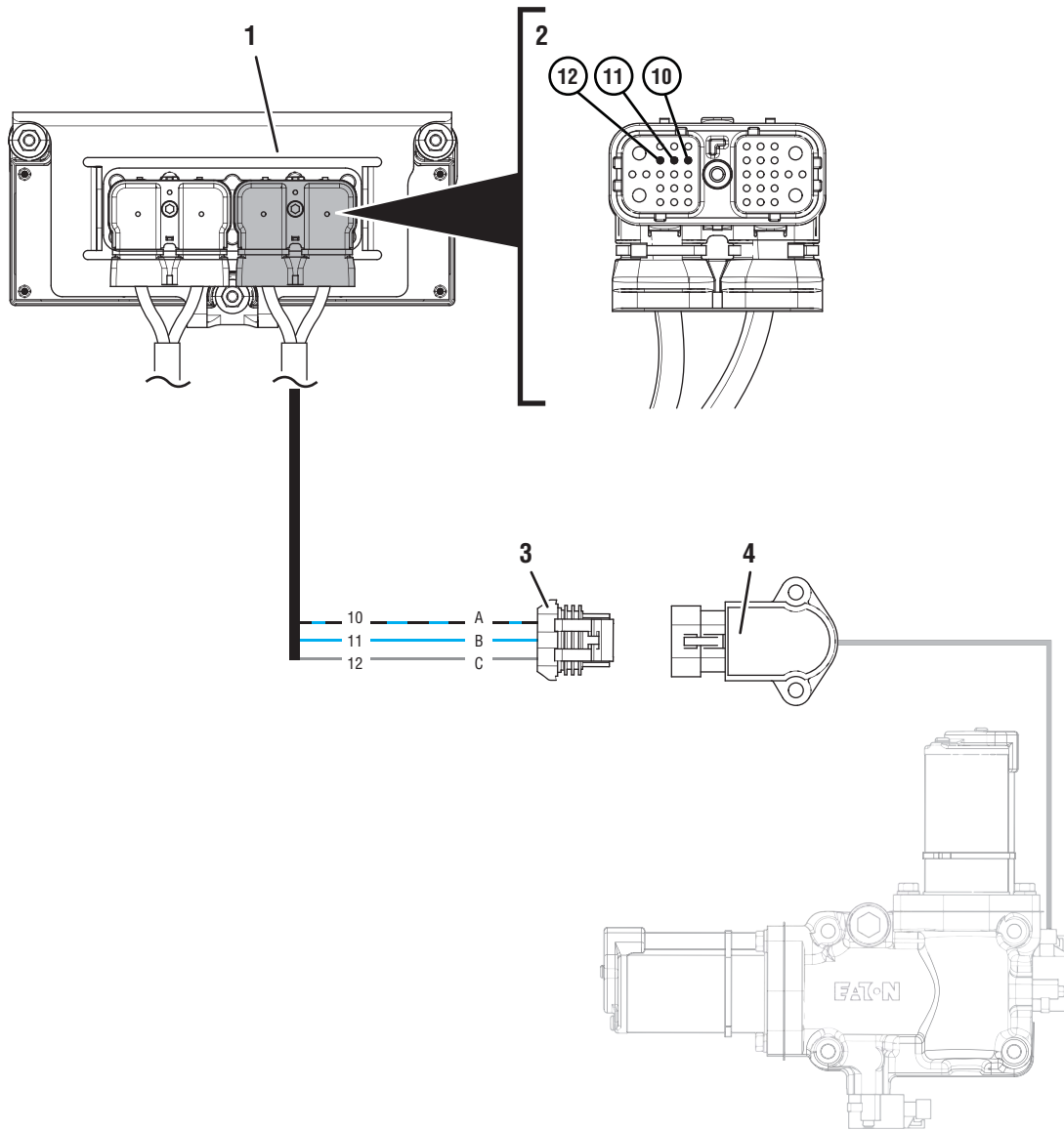

1. Transmission Electronic Control Unit (TECU)
2. 38-Way Transmission Harness Connector
3. 3-Way Gear Position Sensor Connector
4. 3-Way Gear Position Sensor

■ Battery Voltage	■ Switched Battery from TECU	■ Ground	■ Communication	■ Signal
■ Ignition Voltage	■ Switched 5V from TECU	■ Switched Ground	■ Relay/Solenoid Driver	

Fault Code 52 Troubleshooting

A

Purpose: Check for Active or Inactive fault codes.

1. Record the transmission fault codes, FMIs, occurrences, and timestamps from the Service Activity Report created during the Diagnostic Procedure.

Note: check history for **X-Y Shifter** replacement. If recent, replace harness

- If Fault Code 52 FMI 7, 10 is Active, go to **Step C.**
 - If Fault Code 52 FMI 7, 10 is Inactive, go to **Step B.**
 - If Fault Code 52 FMI 2 is Active or Inactive, go to **Step D.**
-

B

Purpose: Use Product Diagnostic (PD) Mode to locate intermittent failures.

1. Set parking brake and chock wheels.
2. Place transmission in PD Mode.

Note: Transmission does not enter PD Mode when Active fault codes exist.



3. Wiggle wiring and connections of the Transmission Harness between the Gear Position Sensor and the TECU. Look for signs of pinched or chafed wiring. Verify all connections are clean and tight.
4. Exit PD Mode by powering down.



IMPORTANT: Allow 2–3 minutes for the TECU to perform a complete power-down sequence before proceeding.

- If any fault codes set Active while wiggling the Transmission Harness, replace Transmission Harness. Go to **Step V.**
 - If no fault codes set Active while wiggling the Transmission Harness, go to **Step C.**
-

Pre-Authorized Warranty Repair Guideline RWRG0074

C *Purpose: Check for short to ground in Rail Position circuit.*

1. Key off.
2. Disconnect 38-Way Transmission Harness Connector from the TECU.
3. Inspect 38-Way Connector body for damage and bent, spread, corroded or loose terminals.
4. Measure resistance between 38-Way Transmission Harness Connector Pin 10 and ground. Record reading(s) in table.

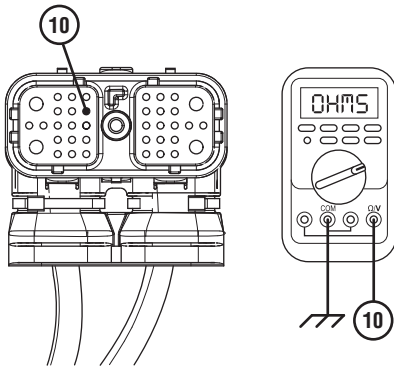

5. Compare reading(s) in table.
 - If connector is damaged, replace Transmission Harness. Go to **Step V.**
 - If readings are in range, go to **Step E.**
 - If readings are out of range, replace Transmission Harness. Go to **Step V.**

Pins	Range	Reading(s)
10 to Ground	Open Circuit (OL)	

D *Purpose: Verify the condition of the 38-Way Transmission Harness Connector.*

1. Key off.
2. Disconnect 38-Way Transmission Harness Connector from the TECU.
3. Verify the connector is free from contamination and corrosion; the terminals are not bent, spread or loose; and there is no damage to the connector body.
4. Inspect the TECU side of the 38-Way Transmission Harness Connector for contamination and corrosion; the terminals are not bent, spread or loose; and there is no damage to the connector body.
 - If no contamination or damage is found, go to **Step E.**
 - If contamination or damage is found, replace the Transmission Harness. Go to **Step V.**

E

Purpose: Verify the proper resistance of the Gear Position Sensor circuit.

1. Key off.
2. Measure resistance between 38-Way Transmission Harness Connector Pin 10 and Pin 11. Record reading(s) in table.

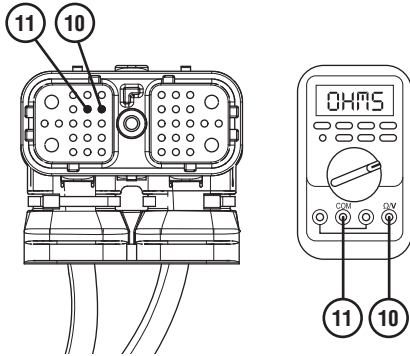

3. Measure resistance between 38-Way Transmission Harness Connector Pin 10 and Pin 12. Record reading(s) in table.

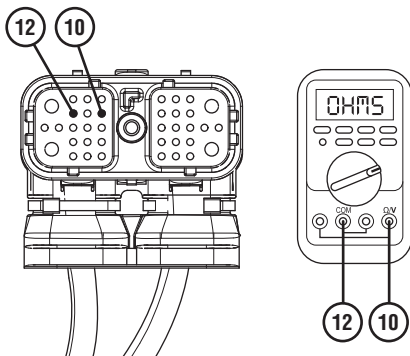

4. Compare reading(s) in table.
 - If all readings are in range, replace Transmission Harness.
 - If either reading is out of range, go to **Step F**.

Pins	Range	Reading(s)
10 to 11	150–200 ohms	
10 to 12	5.5k–6.5k ohms	

Pre-Authorized Warranty Repair Guideline RWRG0074

F *Purpose: Measure the resistance of the Gear Position Sensor.*

1. Key off.
2. Disconnect 3-Way Transmission Harness Connector from the 3-Way Gear Position Sensor.
3. Inspect 3-Way Connector body for damage and bent, spread, corroded or loose terminals.
4. Measure resistance between 3-Way Gear Position Sensor Body Pin A and Pin B. Record reading(s) in table.

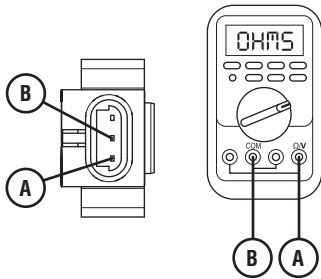

5. Measure resistance between 3-Way Gear Position Sensor Body Pin A and Pin C. Record reading(s) in table.

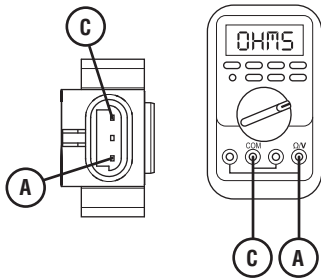

6. Compare reading(s) in table.
 - If the connector is damaged, replace Transmission Harness. Go to **Step V.**
 - If either reading is out of range, replace the X-Y Shifter and Transmission Harness. Go to **Step V.**

Pins	Range	Reading(s)
A to B	150–200 ohms	
A to C	5.5k–6.5k ohms	

V *Purpose: Verify repair.*

1. Key off.
2. Reconnect all connectors and verify that all components are properly installed.
3. Key on with engine off.
4. Clear fault codes using ServiceRanger.
5. Drive vehicle and attempt to reset the code or duplicate the previous complaint.
6. Check for fault codes using ServiceRanger.
 - If no fault codes set Active and vehicle operates properly, test complete.
 - If a fault code other than 52 sets Active, troubleshoot per Correct Transmission Manual.

Pre-Authorized Warranty Repair Guideline RWRG0074

Warranty Parts

- X-Y Shifter
- Transmission Harness

Warranty Labor

- Diagnostics - 0.5 hr
- Check Codes - 0.3 hr
- Software Update if not current version - 0.5 hr
- SRT X-Y Shifter R&R If Required in Troubleshooting
- SRT Transmission Harness R&R
- Road Test - 0.5 hr

Warranty Coding

- Failed Part #: Use Correct PN
- Complaint Code: STUCK IN GEAR
- Failure Code: ROOT CAUSE NOT DETERMINED

Warranty Claim Filing

File pre-authorized warranty claim through appropriate OEM or through Direct Pay.

- RWRG0074
- OEM Warranty Coverage
- Software Revision (from and to)

Note: Repairs that exceed parts and labor parameters cannot be pre-authorized.

Filing through Direct Pay

Click here for Direct Pay submission guidelines and claim forms:



Parts Disposition

Return All Parts Per OEM or Direct Pay Guidelines

Warranty Disclaimer

If the failure is not the result of an accident, damage, negligence, abuse or misuse, improper installation or maintenance or any other conditions described in the Limits and Exclusions section of the Eaton Warranty Manual TCWY0600, then Eaton will treat the condition as covered under its warranty. However, this conclusion does not necessarily mean that a defect in fact exists. In all cases, Eaton shall make the final determination and interpretation as to the warrantability of the product.

RWRG0075 - Input Shaft Speed Sensor Pre-Authorization

Overview

The UltraShift *PLUS* and Fuller Advantage transmissions are equipped with electronic speed sensors. The Input Shaft, Main Shaft and Output Shaft Speed Sensors are used to calculate gear ratios within the transmission. The Input Shaft Speed Sensor measures the rotational speed of the Input Shaft, taken from the upper countershaft drive gear. The Main Shaft Speed Sensor measures the rotational speed of the transmission gearing exiting the main case, taken from the auxiliary upper countershaft gear. The Output Shaft Speed Sensor measures the rotational speed of the output shaft taken from the Output Shaft Tone Wheel. The Transmission Electronic Control Unit (TECU) compares these speeds to calculate the gear ratios of the main case, auxiliary case and overall transmission.

The Input Shaft Speed Sensor transmits a voltage signal to the TECU based on the rotational speed of the Input Shaft entering the transmission main case. The TECU compares Input Shaft Speed to Main Shaft Speed to confirm the gear ratio of the main case and compares Input Shaft Speed to Output Shaft Speed to confirm the overall transmission gear ratio.

Fault Code 56 indicates an electrical fault within the Input Shaft Speed Sensor circuit or a speed value that is inconsistent with the calculated gear ratios.

Note: it has been determined that performing an electrical pre-test is not needed.

Symptom(s)

- "F" flashes in gear display.
- Service light flashes (if equipped).
- Transmission will not engage a gear from neutral.
- Transmission may be limited to down shifts only.
- Transmission operates as normal until neutral gear selection is attained. Once in neutral, the transmission will not engage a start gear.

Warranty Coverage

This Warranty Repair Guideline repair DOES NOT apply if the Fault Code is Inactive and there are other Active Faults in the Eaton/OEM System. If there are other Active Faults, please follow normal troubleshooting procedure using the correct troubleshooting manual per transmission model.

This Pre-Authorization DOES NOT apply if the failed part has been replaced within the last 90 days on the truck.

The warranty coverage varies depending on vehicle vocation and transmission model type. Warranty coverage is the same as that of its respective transmission coverage including extended warranty.

Possible Causes

- Transmission Harness
- Input Shaft Speed Sensor
- Transmission Gear Damage

Pre-Authorized Warranty Repair Guideline RWRG0075

Component Identification

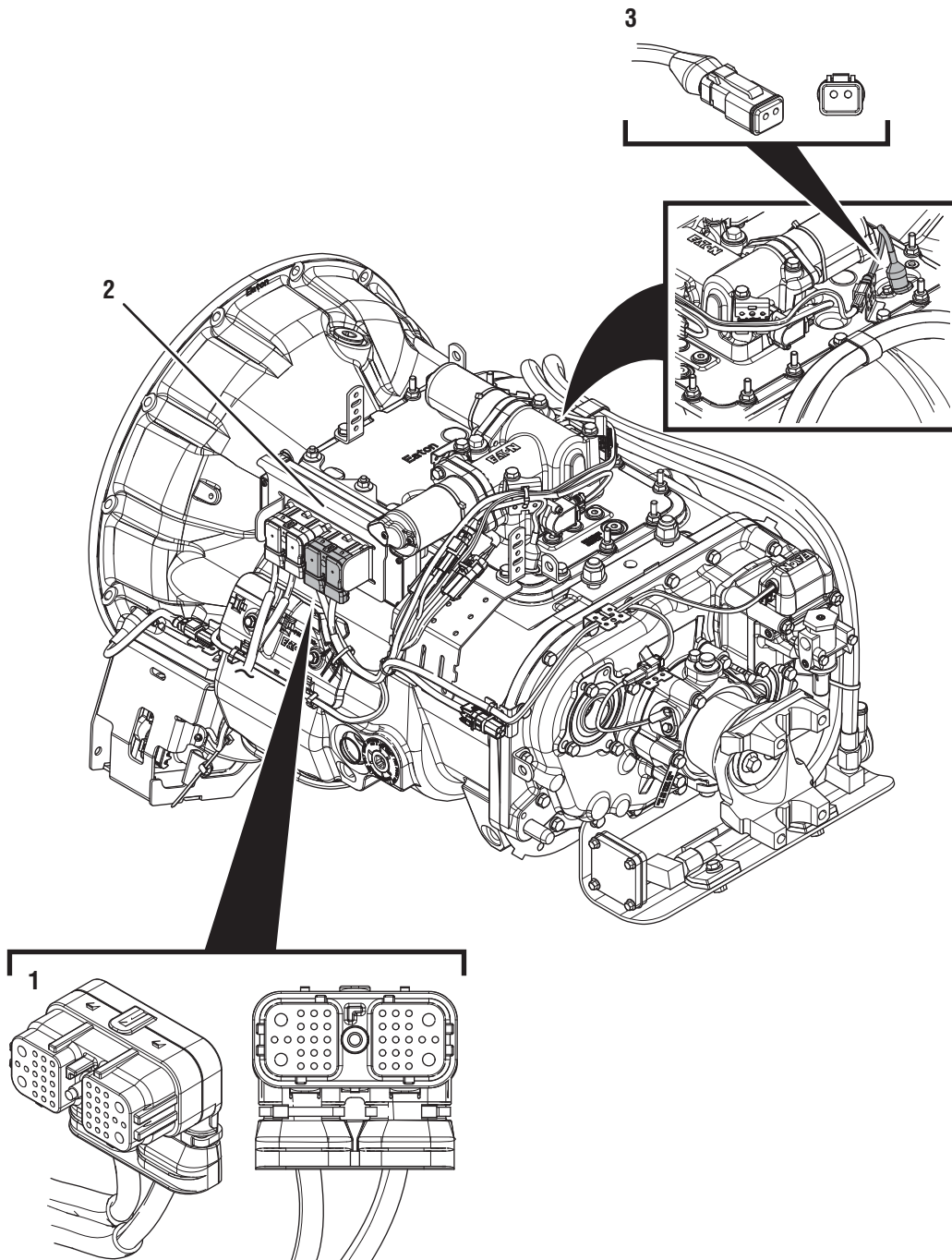

1. 38-Way Transmission Harness Connector
2. Transmission Electronic Control Unit (TECU)
3. 2-Way Input Shaft Speed Sensor

Pre-Authorized Warranty Repair Guideline RWRG0075

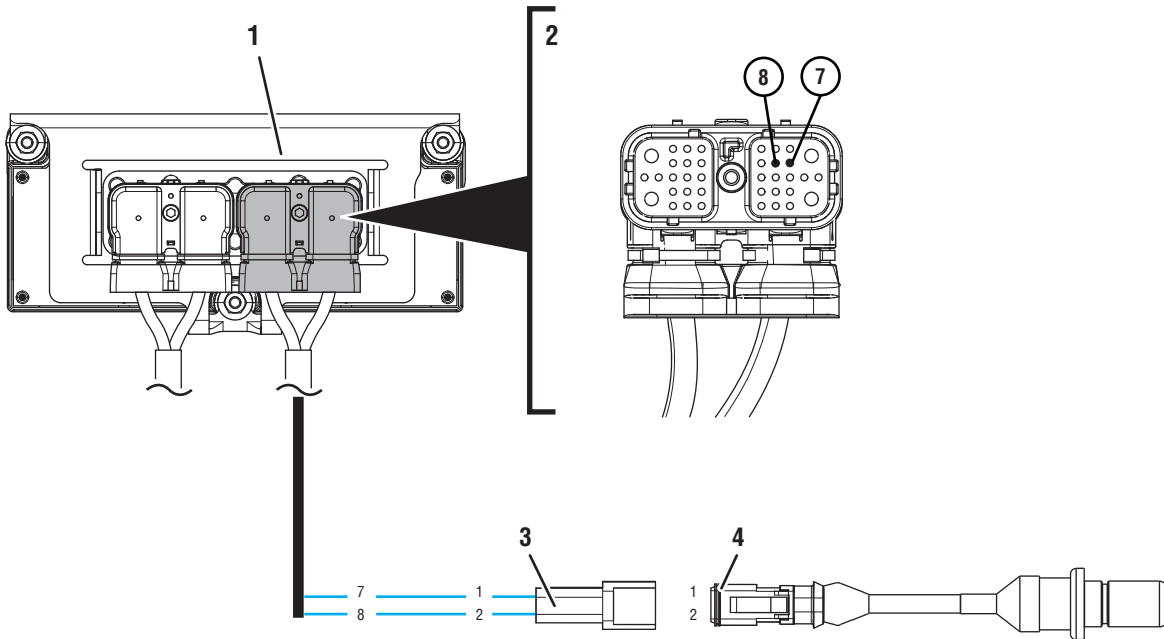

- 1. Transmission Electronic Control Unit (TECU)
- 2. 38-Way Transmission Harness Connector
- 3. 2-Way Input Shaft Speed Sensor Connector
- 4. 2-Way Input Shaft Speed Sensor



Fault Code 56 Troubleshooting

A

Purpose: Check for Active or Inactive fault codes.

1. Record the transmission fault codes, FMIs, occurrences, and timestamps from the Service Activity Report created during the Diagnostic Procedure.

Note: Inspect clutch for caging bolts if Fault Code 56 FMI 2 is Active immediately after start up.

- If Fault Code 56 is Active with FMI 5, go to **Step C.**
- If Fault Code 56 is Inactive with FMI 2, but sets active after attempting a gear, go to **Step D.**
- If Fault Code 56 is Inactive, engages a gear with FMI 2 or 5, and is intermittent complaint go to go to **Step B.**

B

Purpose: Replace Transmission Harness and Input Shaft Speed Sensor.

1. Key off, set parking brake and chock wheels.
 - Replace Transmission Harness and Input Shaft Speed Sensor. Go to **Step V.**

C

Purpose: Verify continuity of Input Shaft Speed Sensor circuit and no continuity to ground.

1. Key off, set parking brake and chock wheels.
 - Replace transmission harness and Input Speed Sensor. Go to **Step V.**

D

Purpose: Verify no internal damage.

1. Remove PTO cover and inspect for mechanical damage.

Note: Drain fluid into clean pan for reuse. replacement fluid is non-warrantable.

- If damage found, contact Realtime Warranty for further assistance. Go to **Step V.**

Pre-Authorized Warranty Repair Guideline RWRG0075

V

Purpose: Verify repair.

1. Key off.
2. Reconnect all connectors and verify that all components are properly installed.
3. Key on with engine off.
4. Clear fault codes using ServiceRanger.
5. Drive vehicle and attempt to reset the code or duplicate the previous complaint.
6. Check for fault codes using ServiceRanger.
 - If no fault codes set Active and vehicle operates properly, test complete.
 - If Fault Code 56 sets Active during the test drive, utilize roadranger.com for further troubleshooting options.
 - If a fault code other than 56 sets, troubleshoot using appropriate troubleshooting manual.

Warranty Parts

- K-4148 Speed Sensor
- Transmission Harness
- PTO Cover Gaskets (if needed)

Warranty Labor

- PTO Cover R&R (if Step D completed)
Or
- PTO R&R (If Step D completed)
- Software Update if not current revision - 0.5hr
- SRT Input Speed Sensor
- SRT Transmission Harness

Warranty Coding

- Failed Part #: Kit Number Used
- Complaint Code: ENGAGEMENT - WONT GO INTO GEAR
- Failure Code: ROOT CAUSE NOT DETERMINED

Warranty Claim Filing

File pre-authorized warranty claim through appropriate OEM or through Direct Pay.

- RWRG0075
- OEM Warranty Coverage
- Software Revision (from and to)
- Photos of PTO if installed on unit

Filing through Direct Pay

Click here for Direct Pay submission guidelines and claim forms:



**Submission Guidelines
and Claim Forms**

Parts Disposition

Return All Parts Per OEM or Direct Pay Guidelines.

Warranty Disclaimer

If the failure is not the result of an accident, damage, negligence, abuse or misuse, improper installation or maintenance or any other conditions described in the Limits and Exclusions section of the Eaton Warranty Manual TCWY0600, then Eaton will treat the condition as covered under its warranty. However, this conclusion does not necessarily mean that a defect in fact exists. In all cases, Eaton shall make the final determination and interpretation as to the warrantability of the product.

RWRG0076 - Main Shaft Speed Sensor Pre-Authorization

Overview

The UltraShift *PLUS* and Fuller Advantage transmissions are equipped with four electronic speed sensors. The Input Shaft, Main Shaft and Output Shaft Speed Sensors are used to calculate gear ratios within the transmission. The Input Shaft Speed Sensor measures the rotational speed of the Input Shaft, taken from the upper countershaft drive gear. The Main Shaft Speed Sensor measures the rotational speed of the transmission gearing exiting the main case, taken from the auxiliary upper countershaft gear. The Output Shaft Speed Sensor measures the rotational speed of the output shaft taken from the Output Shaft Tone Wheel. The Transmission Electronic Control Unit (TECU) compares these speeds to calculate the gear ratios of the main case, auxiliary case and overall transmission.

The Main Shaft Speed Sensor transmits a voltage signal to the TECU based on the rotational speed of the gearing exiting the transmission main case. The TECU compares Main Shaft Speed to Input Shaft Speed to confirm the gear ratio of the main case and compares Main Shaft Speed to Output Shaft Speed to confirm the gear ratio of the auxiliary case.

Fault Code 57 indicates an electrical fault within the Main Shaft Speed Sensor circuit or a speed value that is inconsistent with the calculated gear ratios.

Note: it has been determined that performing an electrical pre-test is not needed.

Symptom(s)

- “F” flashes in gear display.
- Service light flashes (if equipped).
- If fault occurs in low range, transmission will not complete a high range shift.
- If fault occurs in high range, transmission will down shift into low range, but will not shift back into high range.

Warranty Coverage

This Warranty Repair Guideline repair DOES NOT apply if the Fault Code is Inactive and there are other Active Faults in the Eaton/OEM System. If there are other Active Faults, please follow normal troubleshooting procedure using the correct troubleshooting manual per transmission model.

This Pre-Authorization DOES NOT apply if the failed part has been replaced within the last 90 days on the truck.

The warranty coverage varies depending on vehicle vocation and transmission model type. Warranty coverage is the same as that of its respective transmission coverage including extended warranty.

Possible Causes

- Transmission Harness
- Main Shaft Speed Sensor
- Transmission Gear Damage

Component Identification

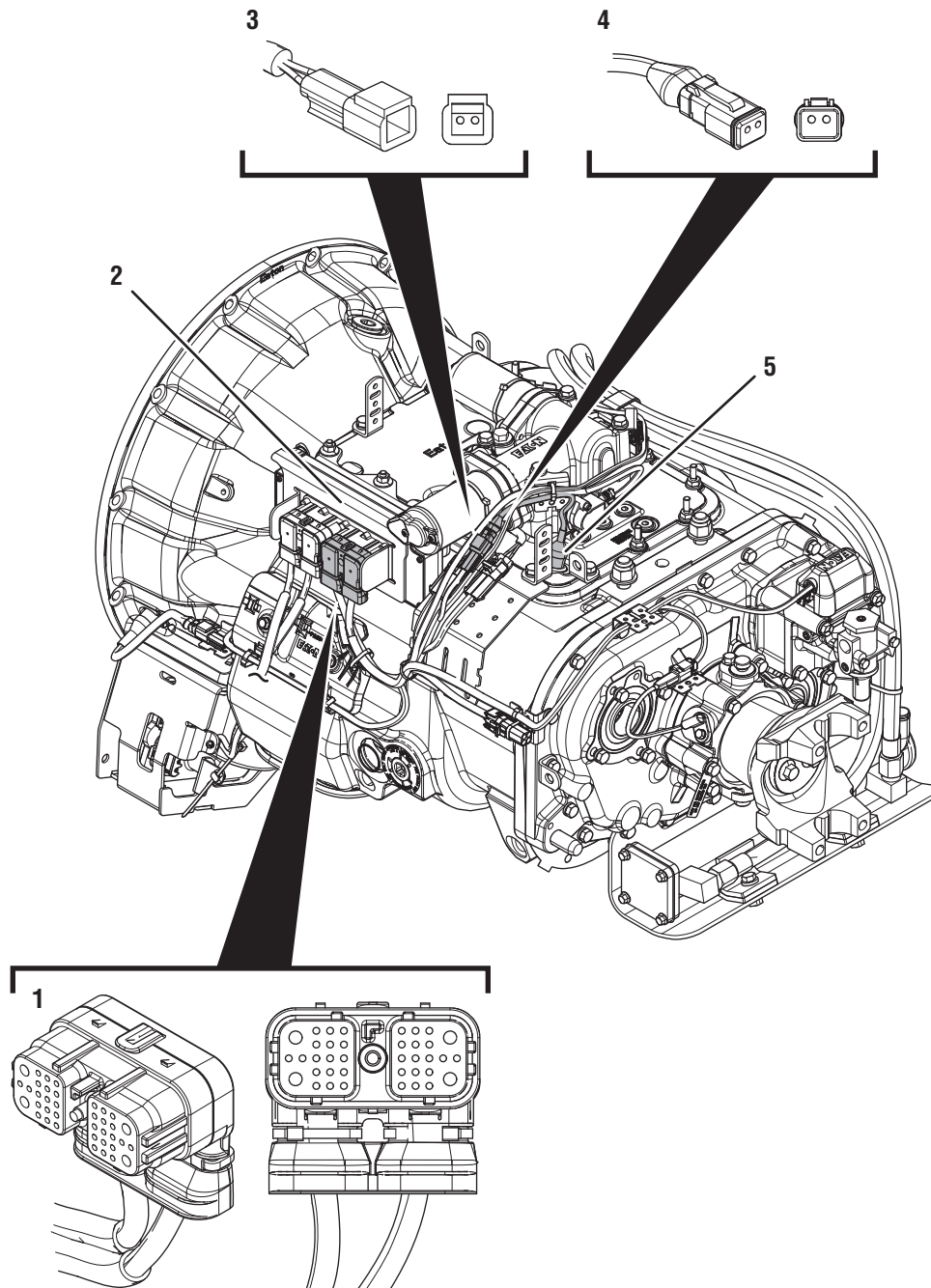

1. 38-Way Transmission Harness Connector
2. Transmission Electronic Control Unit (TECU)
3. 2-Way Main Shaft Speed Sensor Connector Body
4. 2-Way Main Shaft Speed Sensor
5. Main Shaft Speed Sensor

Pre-Authorized Warranty Repair Guideline RWRG0076

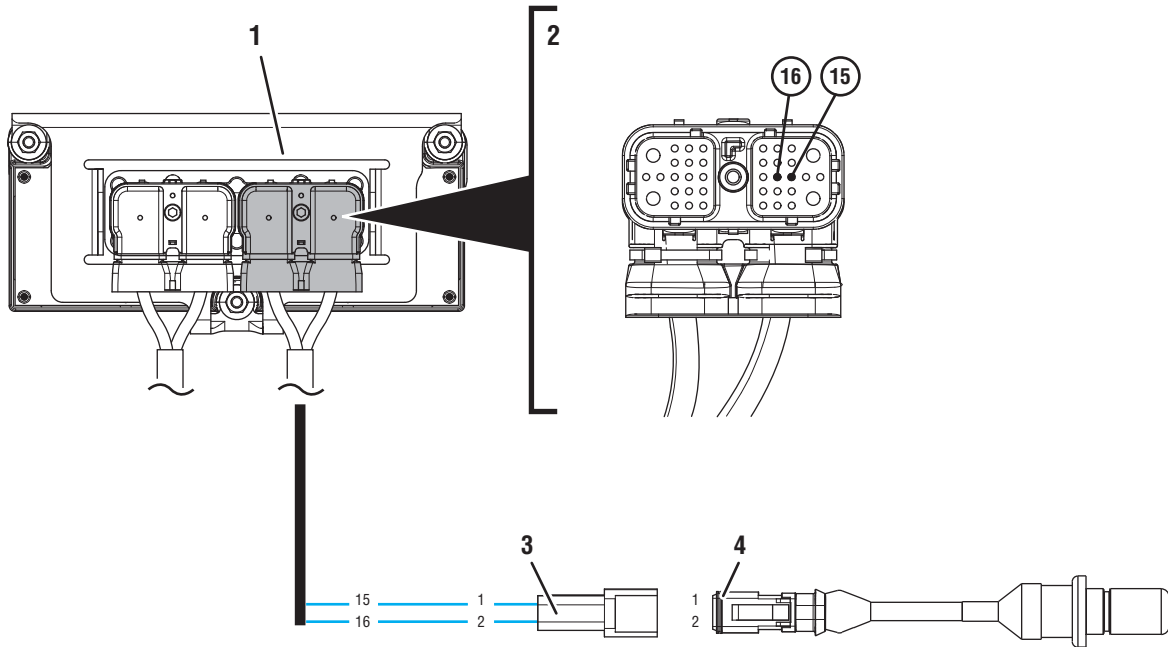

1. Transmission Electronic Control Unit (TECU)
2. 38-Way Transmission Harness Connector
3. 2-Way Main Shaft Speed Sensor Connector Body
4. 2-Way Main Shaft Speed Sensor



Fault Code 57 Troubleshooting

A

Purpose: Check for Active or Inactive fault codes.

1. Record the transmission fault codes, FMIs, occurrences, and timestamps from the Service Activity Report created during the Diagnostic Procedure.

Note: Inspect clutch for caging bolts if FMI 2 Active after start up.

- If Fault Code 57 is Active with FMI 5, go to **Step C.**
- If Fault Code 57 is Inactive with FMI 2, but sets active after attempting a gear, go to **Step D.**
- If Fault Code 57 with FMI 2 or 5 is Inactive, engages a gear, and is an intermittent complaint go to **Step B.**

B

Purpose: Replace Transmission Harness and Main Shaft Speed Sensor.

1. Key off, set parking brake and chock wheels.
 - Replace Transmission Harness and Main Shaft Speed Sensor. Go to **Step V.**
-

C

Purpose: Verify continuity of Main Shaft Speed Sensor circuit and no continuity to ground.

1. Key off, set parking brake and chock wheels.
 - Replace Transmission Harness and Main Shaft Speed Sensor. Go to **Step V.**

D

Purpose: Verify no internal damage.

1. Remove 8-Bolt PTO cover and inspect for mechanical damage.

Note: Drain fluid into clean pan for reuse. replacement fluid is non-warrantable.

- If damage found, contact Realtime Warranty for further assistance. go to **Step V.**
-

Pre-Authorized Warranty Repair Guideline RWRG0076

V

Purpose: Verify repair.

1. Key off.
2. Reconnect all connectors and verify that all components are properly installed.
3. Key on with engine off.
4. Clear fault codes using ServiceRanger.
5. Drive vehicle and attempt to reset the code or duplicate the previous complaint.
6. Check for fault codes using ServiceRanger.
 - If no fault codes set Active and vehicle operates properly, test complete.
 - If Fault Code 57 sets Active during the test drive, utilize roadranger.com for further troubleshooting options.
 - If a fault code other than 57 sets, troubleshoot using appropriate troubleshooting manual.

Warranty Parts

- K-4148 Speed Sensor
- Transmission Harness
- PTO Cover Gaskets (if applicable)

Warranty Labor

- PTO Cover R&R (if Step D completed)
Or
- PTO R&R (If Step D completed)
- Software Update if not current revision - 0.5hr
- SRT Input Speed Sensor
- SRT Transmission Harness

Warranty Coding

- Failed Part #: Kit Number Used
- Complaint Code: ENGAGEMENT - WONT GO INTO GEAR
- Failure Code: ROOT CAUSE NOT DETERMINED

Warranty Claim Filing

File pre-authorized warranty claim through appropriate OEM or through Direct Pay.

- RWRG0076
- OEM Warranty Coverage
- Software Revision (from and to)
- Photos of PTO if installed on unit

Filing through Direct Pay

Click here for Direct Pay submission guidelines and claim forms:



**Submission Guidelines
and Claim Forms**

Parts Disposition

Return All Parts Per OEM or Direct Pay Guidelines.

Warranty Disclaimer

If the failure is not the result of an accident, damage, negligence, abuse or misuse, improper installation or maintenance or any other conditions described in the Limits and Exclusions section of the Eaton Warranty Manual TCWY0600, then Eaton will treat the condition as covered under its warranty. However, this conclusion does not necessarily mean that a defect in fact exists. In all cases, Eaton shall make the final determination and interpretation as to the warrantability of the product.

RWRG0077 - Fault Code 61 Pre-Authorization

Overview

The UltraShift *PLUS* Transmission is equipped with an X-Y Shifter that selects a transmission gear. The X-Y Shifter motors are controlled with electrical current supplied by the TECU to move the Shift Finger either side-to-side (rail selection) or fore-and-aft (gear engagement and disengagement). Fault Code 61 indicates a failure with the circuit controlling the Rail Motor and the side-to-side movement of the X-Y Shift Finger.

Note: it has been determined that performing an electrical pre-test is not needed.

Symptom(s)

- “F” flashes in gear display.
- Service light flashes (if equipped).
- Engine may not crank.
- Transmission may not engage a gear from neutral.
- Transmission does not shift while vehicle is moving.
- Until fault becomes Inactive, driver may have to shut off engine with transmission in gear.

Warranty Coverage

This Warranty Repair Guideline repair DOES NOT apply if the Fault Code is Inactive and there are other Active Faults in the Eaton/OEM System. If there are other Active Faults, please follow normal troubleshooting procedure using the correct troubleshooting manual per transmission model.

This Pre-Authorization DOES NOT apply if the failed part has been replaced within the last 90 days on the truck.

This Pre-Authorization DOES NOT apply if the failed component is mounted to a Medium Duty transmission.

The warranty coverage varies depending on vehicle vocation and transmission model type. Warranty coverage is the same as that of its respective transmission coverage including extended warranty.

Possible Causes

FMI 1, 5

- Transmission Harness
- X-Y Shifter Rail Motor

Component Identification

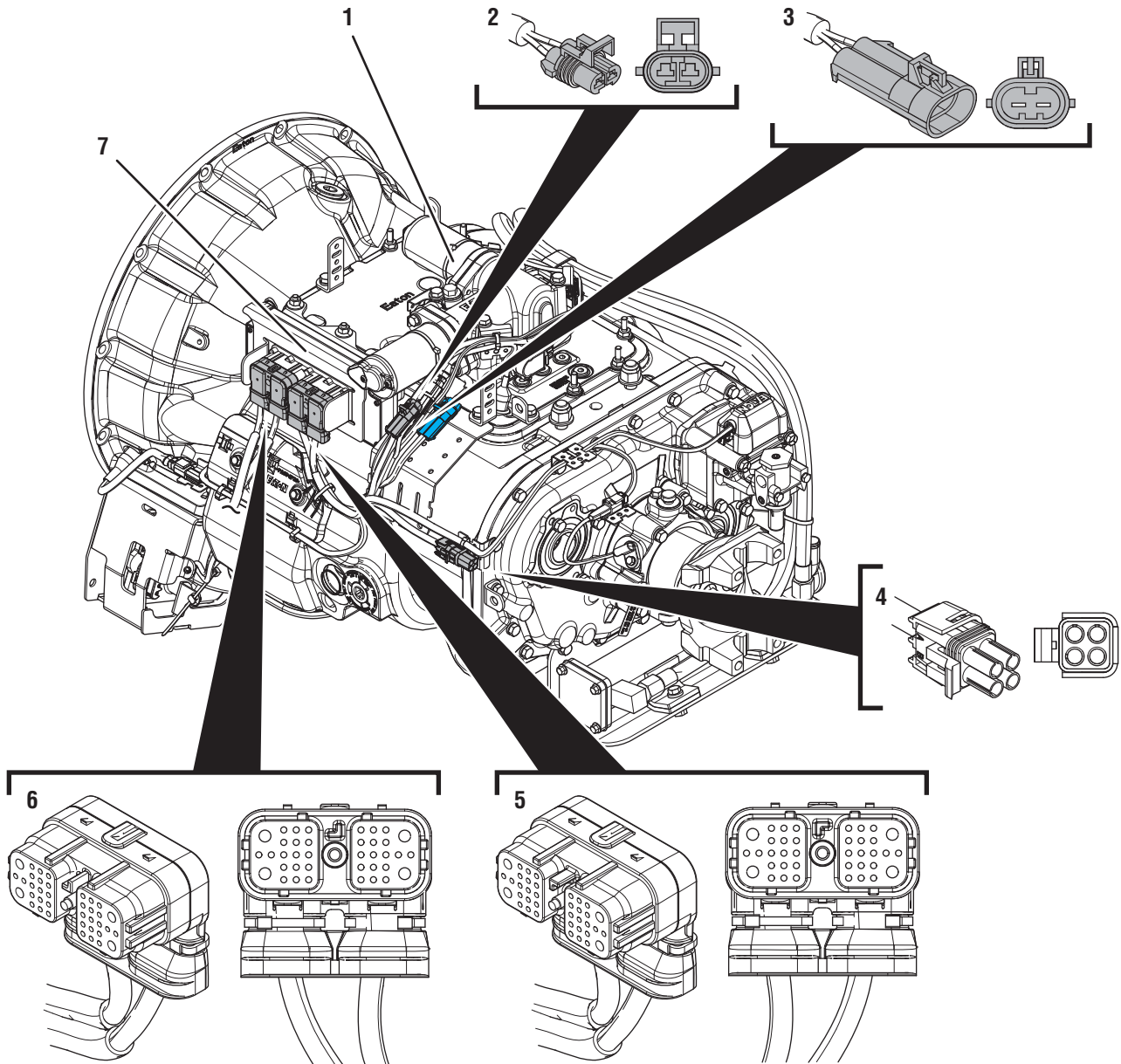

1. X-Y Shifter
2. 2-Way Rail Motor Connector (black)
3. 2-Way Rail Motor Connector Body (black)
4. 4-Way Diagnostic Connector
5. 38-Way Transmission Harness Connector
6. 38-Way Vehicle Harness Connector
7. Transmission Electronic Control Unit (TECU)

Pre-Authorized Warranty Repair Guideline RWRG0077

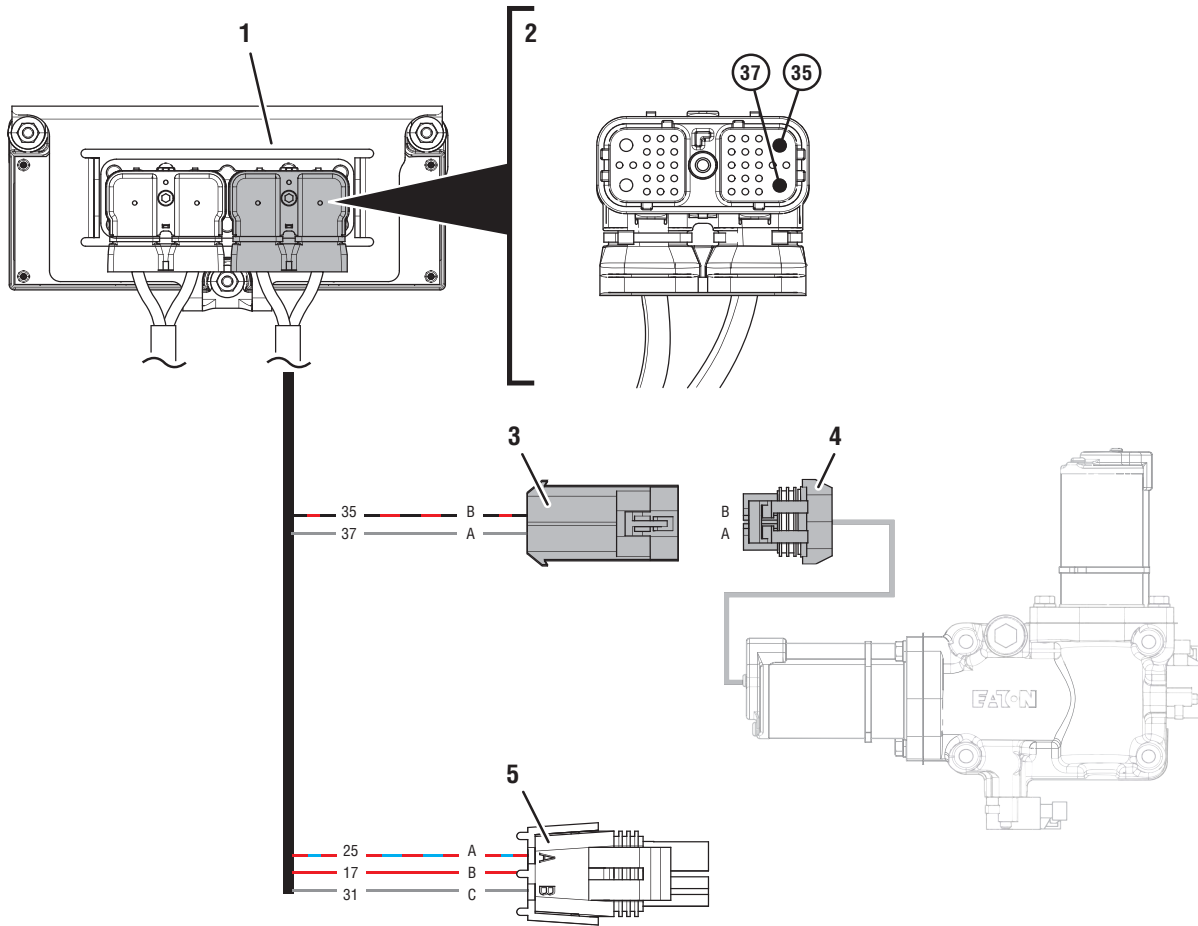

1. Transmission Electronic Control Unit (TECU)
2. 38-Way Transmission Harness Connector
3. 2-Way Rail Motor Connector Body (black)
4. 2-Way Rail Motor Connector (black)
5. 4-Way Diagnostic Connector

 Battery Voltage	 Switched Battery from TECU	 Ground	 Communication	 Signal
 Ignition Voltage	 Switched 5V from TECU	 Switched Ground	 Relay/Solenoid Driver	

Fault Code 61 Troubleshooting

A

Purpose: Check for Active or Inactive fault codes.

1. Record the transmission fault codes, FMIs, occurrences, and timestamps from the Service Activity Report created during the Diagnostic Procedure. Determine Fault Code 61 FMI 1 or 5.
 - If Fault Code 61 FMI 1 is active or inactive, go to **Step B.**
 - If Fault Code 61 FMI 5 is active or inactive, remove X-Y Shifter and inspect for coolant contamination. If contamination is found, service per RWRG0005.
 - if no contamination, replace X-Y shifter and Transmission Harness, go to **Step V.**

B

Purpose: Verify if FMI 1 is set Active/Inactive.

1. Determine Fault Code FMIs.

Note: Key on active FMI 1 does not apply to this pre-authorization.

 - If FMI 1 is inactive. Replace X-Y Shifter. If it is Key on Active, proceed with Normal troubleshooting methods found in appropriate manual. Go to **Step V.**
-

V

Purpose: Verify repair.

1. Key off.
 2. Reconnect all connectors and verify that all components are properly installed.
 3. Key on with engine off.
 4. Clear fault codes using ServiceRanger.
 5. Drive vehicle and attempt to reset the code or duplicate the previous complaint.
 6. Check for fault codes using ServiceRanger.
 - If no fault codes set and vehicle operates properly, test complete.
 - If fault code 61 sets Active during test drive, return to transmission specific diagnostic manual for extended trouble shooting.
 - If a fault code other than 61 sets, troubleshoot using appropriate troubleshooting manual.
-

Pre-Authorized Warranty Repair Guideline RWRG0077

Warranty Parts

- K-4223RX: X-Y Shifter
- P/N Varies: Transmission Harness Kit

Warranty Labor

- Diagnostics - 0.3 hr
- Software Update if not current version - 0.5 hr
- SRT Transmission Harness R&R
- SRT X-Y Shifter R&R
- Road Test - 0.5 hr

Warranty Coding

- Part: A-7856
- Complaint: STUCK IN GEAR
- Failure: ROOT CAUSE NOT DETERMINED

Warranty Claim Filing

File pre-authorized warranty claim through appropriate OEM or through Direct Pay.

- RWRG0077
- OEM Warranty Coverage
- Software Revision (from and to)
- XY Shifter and Transmission Harness Kit used

Filing through Direct Pay

Click here for Direct Pay submission guidelines and claim forms:



Parts Disposition

Return Parts per OEM or Direct Pay guidelines.

Warranty Disclaimer

If the failure is not the result of an accident, damage, negligence, abuse or misuse, improper installation or maintenance or any other conditions described in the Limits and Exclusions section of the Eaton Warranty Manual TCWY0600, then Eaton will treat the condition as covered under its warranty. However, this conclusion does not necessarily mean that a defect in fact exists. In all cases, Eaton shall make the final determination and interpretation as to the warrantability of the product.

RWRG0078 - Fault Code 63 Pre-Authorization

Overview

The UltraShift *PLUS* transmission is equipped with an X-Y Shifter that selects a transmission gear. The X-Y Shifter motors are controlled with electrical current supplied by the TECU to move the Shift Finger either side-to-side (rail selection) or fore-and-aft (gear engagement and disengagement). Fault Code 63 indicates a failure of the circuit controlling the Gear Motor and the fore-and-aft movement of the X-Y Shift Finger.

Note: it has been determined that performing an electrical pre-test is not needed.

Symptom(s)

- “F” flashes in gear display.
- Service light flashes (if equipped).
- Engine may not crank.
- Transmission may not engage a gear from neutral.
- Transmission does not shift while the vehicle is moving.
- Until the fault becomes Inactive, driver may have to shut off engine with transmission in gear.

Warranty Coverage

This Warranty Repair Guideline repair DOES NOT apply if the Fault Code is Inactive and there are other Active Faults in the Eaton/OEM System. If there are other Active Faults, please follow normal troubleshooting procedure using the correct troubleshooting manual per transmission model.

This Pre-Authorization DOES NOT apply if the failed part has been replaced within the last 90 days on the truck.

This Pre-Authorization DOES NOT apply if the failed component is mounted to a Medium Duty transmission.

The warranty coverage varies depending on vehicle vocation and transmission model type. Warranty coverage is the same as that of its respective transmission coverage including extended warranty.

Possible Causes

FMI 1, 5

- Transmission Harness
- X-Y Shifter Gear Motor

Component Identification

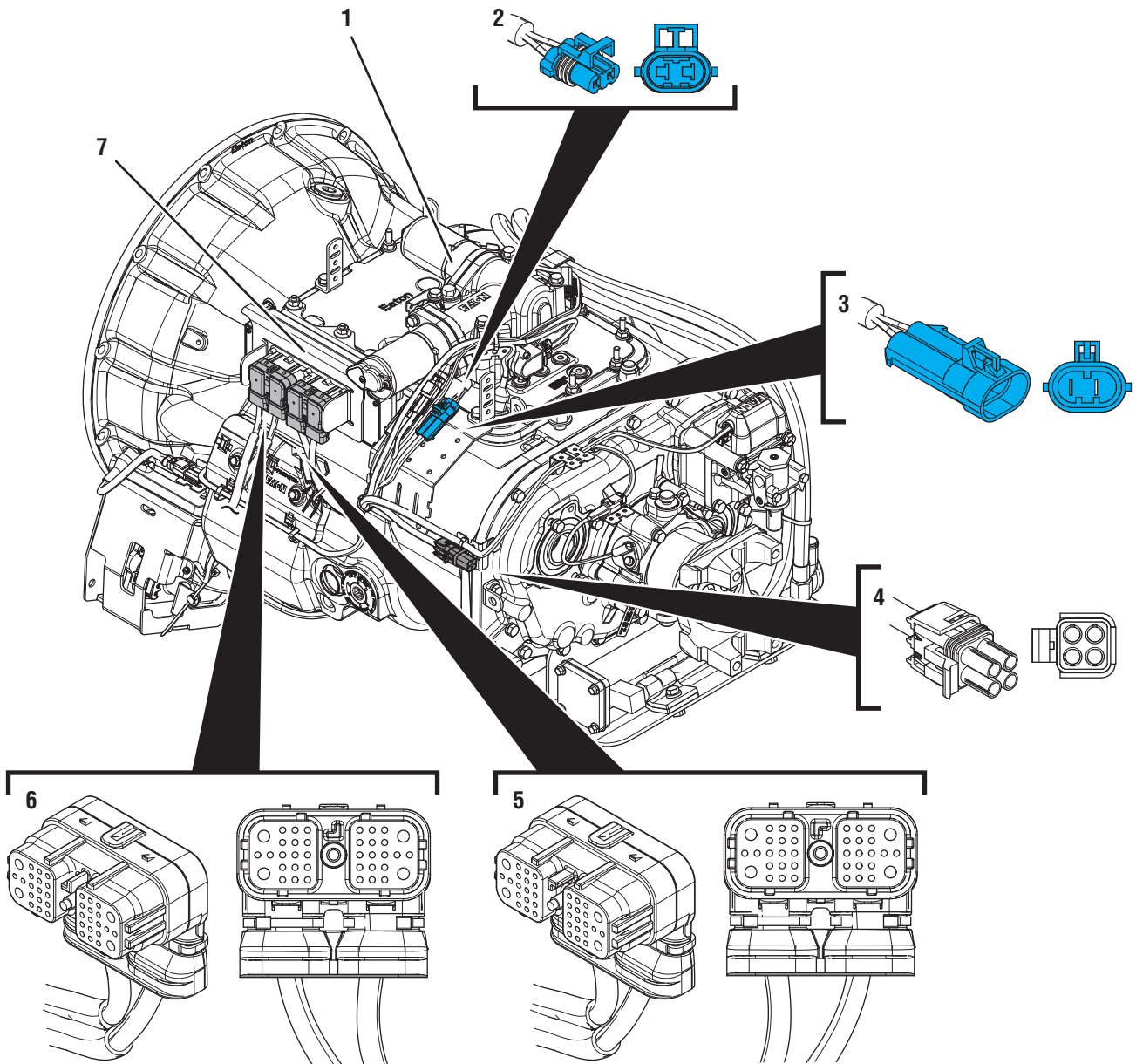

- 1. X-Y Shifter
- 2. 2-Way Gear Motor Connector (blue)
- 3. 2-Way Gear Motor Connector Body (blue)
- 4. 4-Way Diagnostic Connector
- 5. 38-Way Transmission Harness Connector
- 6. 38-Way Vehicle Harness Connector
- 7. Transmission Electronic Control Unit (TECU)

Pre-Authorized Warranty Repair Guideline RWRG0078

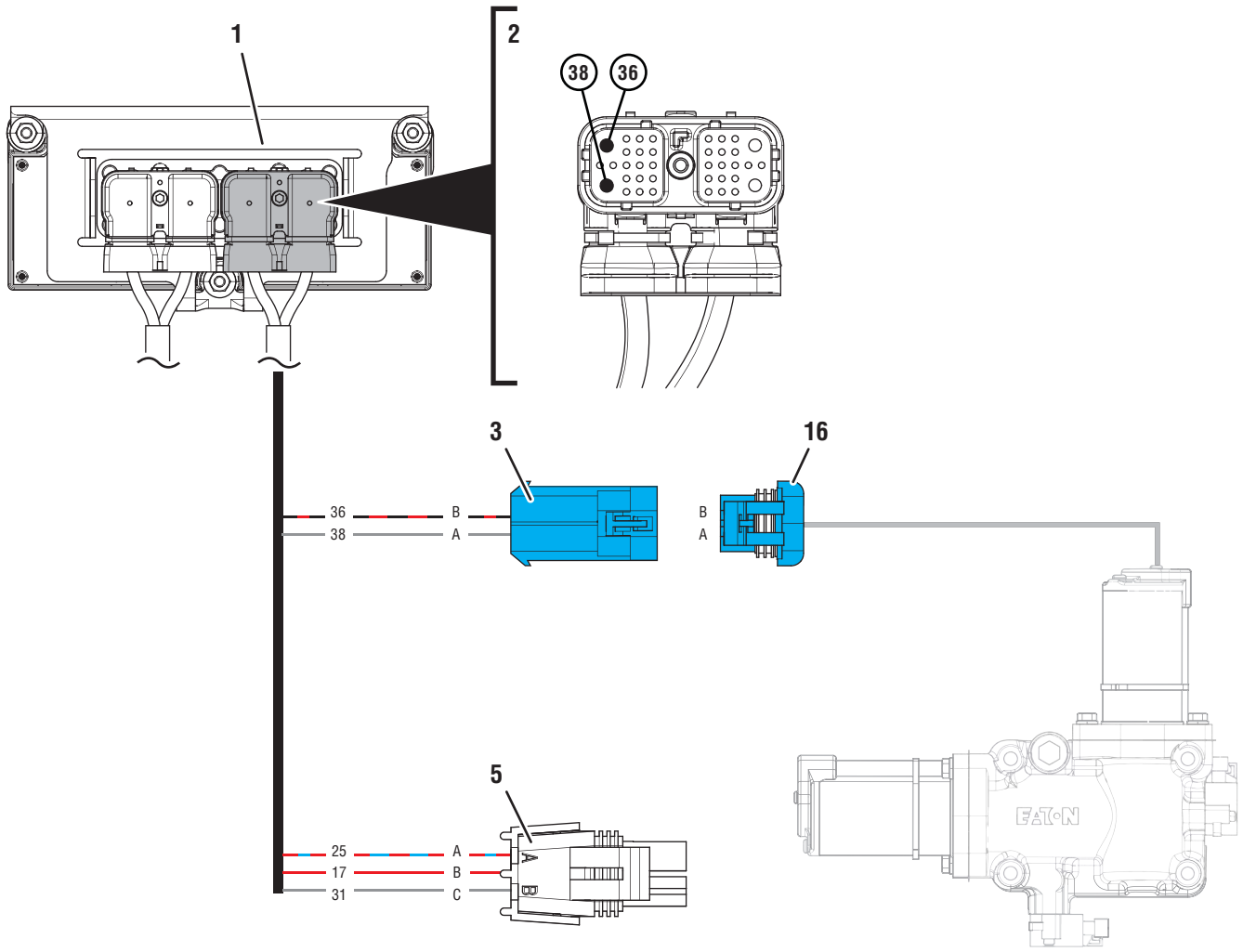

- 1. Transmission Electronic Control Unit (TECU)
- 2. 38-Way Transmission Harness Connector
- 3. 2-Way Gear Motor Connector Body (blue)
- 4. 2-Way Gear Motor Connector (blue)
- 5. 4-Way Diagnostic Connector

 Battery Voltage	 Switched Battery from TECU	 Ground	 Communication	 Signal
 Ignition Voltage	 Switched 5V from TECU	 Switched Ground	 Relay/Solenoid Driver	

Fault Code 63 Troubleshooting

A

Purpose: Check for Active or Inactive fault codes.

1. Record the transmission fault codes, FMIs, occurrences, and timestamps from the Service Activity Report created during the Diagnostic Procedure. Determine Fault Code 63 FMI 1 or 5.
 - If Fault Code 63 FMI 1 is active or inactive, go to **Step B.**
 - If Fault Code 63 FMI 5 is active or inactive, remove X-Y Shifter and inspect for coolant contamination. If contamination is found, service per RWRG0005.
 - if no contamination, replace X-Y shifter and Transmission Harness, go to **Step V.**

B

Purpose: Verify if FMI 1 is set Active/Inactive.

1. Determine Fault Code FMIs.
 - If FMI 1 is inactive. Replace X-Y Shifter. If it is Key on Active, proceed with Normal troubleshooting methods found in appropriate manual. Go to **Step V.**

V

Purpose: Verify repair.

1. Key off.
2. Reconnect all connectors and verify that all components are properly installed.
3. Key on with engine off.
4. Clear fault codes using ServiceRanger.
5. Drive vehicle and attempt to reset the code or duplicate the previous complaint.
6. Check for fault codes using ServiceRanger.
 - If no fault codes set and vehicle operates properly, test complete.
 - If Fault Code 63 sets Active during the test drive, return to transmission specific diagnostic manual for extended trouble shooting.
 - If a fault code other than 63 sets, troubleshoot using appropriate troubleshooting manual.

Pre-Authorized Warranty Repair Guideline RWRG0078

Warranty Parts

- K-4223RX: X-Y Shifter
- P/N Varies: Transmission Harness

Warranty Labor

- Diagnostics - 0.3 hr
- Software Update if not current version - 0.5 hr
- SRT Transmission Harness R&R
- SRT X-Y Shifter R&R
- Road Test - 0.5 hr

Warranty Coding

- Part: A-7856
- Complaint: STUCK IN GEAR
- Failure: ROOT CAUSE NOT DETERMINED

Warranty Claim Filing

File pre-authorized warranty claim through appropriate OEM or through Direct Pay.

- RWRG0078
- OEM Warranty Coverage
- Software Revision (from and to)
- XY Shifter and Transmission Harness Kit used

Filing through Direct Pay

Click here for Direct Pay submission guidelines and claim forms:



Parts Disposition

Return Parts per OEM or Direct Pay guidelines.

Warranty Disclaimer

If the failure is not the result of an accident, damage, negligence, abuse or misuse, improper installation or maintenance or any other conditions described in the Limits and Exclusions section of the Eaton Warranty Manual TCWY0600, then Eaton will treat the condition as covered under its warranty. However, this conclusion does not necessarily mean that a defect in fact exists. In all cases, Eaton shall make the final determination and interpretation as to the warrantability of the product.

RWRG0079 - Generation 1 Electronic Clutch Actuator (ECA) Only Pre-Authorized Fault Code 65 Repair Guideline

Overview

The UltraShift *PLUS* transmission is equipped with an Electronic Clutch Actuator (ECA) Speed Sensor that provides a secondary engine speed signal to the Transmission Electronic Control Unit (TECU). The ECA Speed Sensor is installed in the clutch housing. The ECA broadcasts the ECA Speed Sensor signal to the TECU through the High Integrity Link (HIL) contained within the transmission harness.

The TECU uses the ECA Speed Sensor signal to determine engine speed when the J1939 engine speed signal is not available. Early models have a thread-in ECA Speed Sensor installed in the flywheel housing. Fault Code 65 indicates either a loss of the signal or an electrical issue with the ECA Speed Sensor.

Note: it has been determined that performing an electrical pre-test is not needed.

Symptom(s)

- “F” flashes in gear display.
- Service light flashes (if equipped).
- No fallback mode is associated with this fault. TECU uses the vehicle engine speed signal, broadcast over J1939, to operate the transmission.

Warranty Coverage

This Warranty Repair Guideline repair DOES NOT apply if the Fault Code is Inactive and there are other Active Faults in the Eaton/OEM System. If there are other Active Faults, please follow normal troubleshooting procedure using the correct troubleshooting manual per transmission model.

This Pre-Authorization DOES NOT apply if the failed part has been replaced within the last 90 days on the truck.

The warranty coverage varies depending on vehicle vocation and transmission model type. Warranty coverage is the same as that of its respective transmission coverage including extended warranty.

Possible Causes

Note: Generation 1 only.

FMI 2

- ECA Speed Sensor
- ECA

FMI 5

- ECA Speed Sensor
- Transmission Harness
- ECA

Pre-Authorized Warranty Repair Guideline RWRG0079

Component Identification

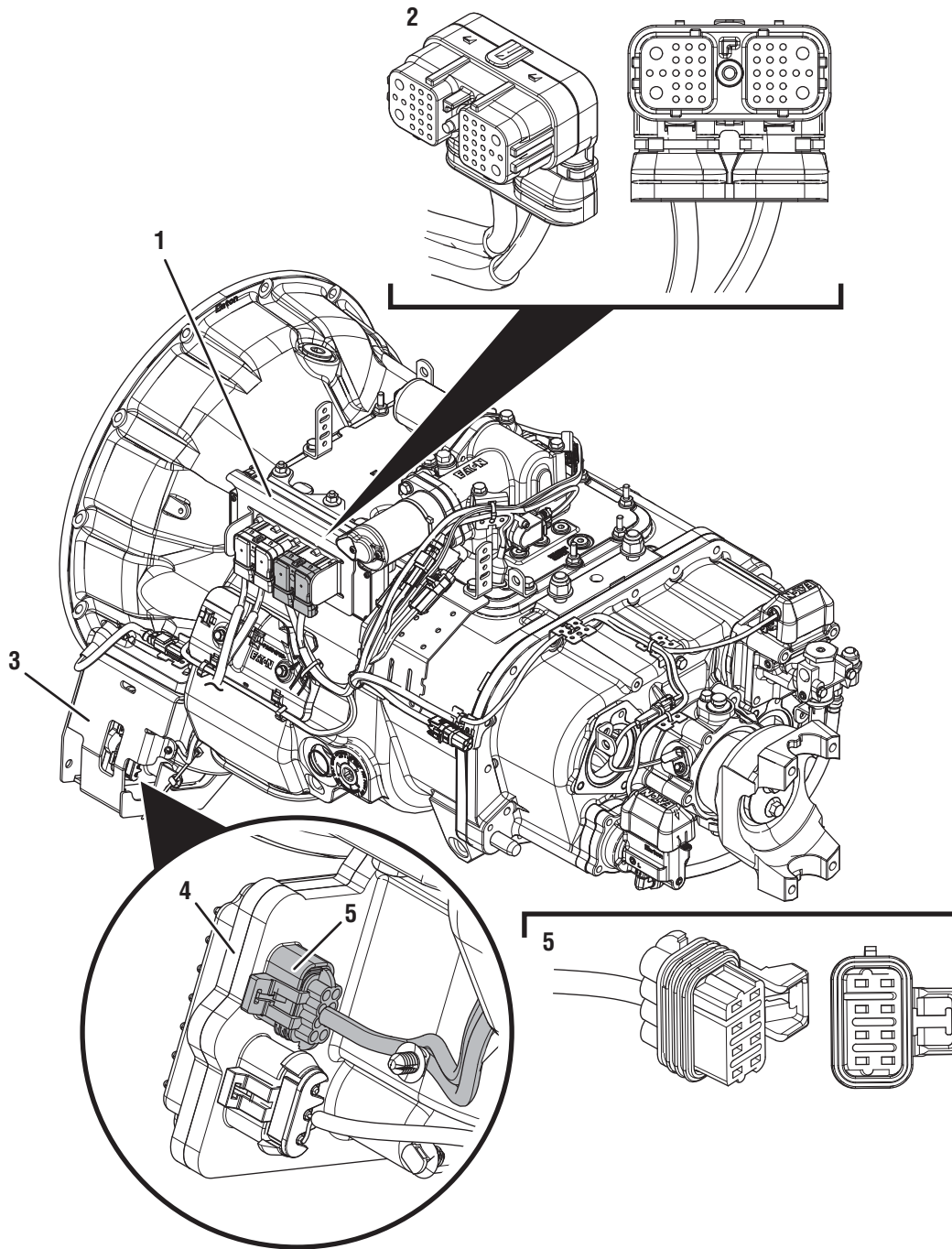

- 1. Transmission Electronic Control Unit (TECU)
- 2. 38-Way Transmission Harness Connector
- 3. ECA Shield
- 4. Electronic Clutch Actuator (ECA)
- 5. 8-Way ECA Connector

Pre-Authorized Warranty Repair Guideline RWRG0079

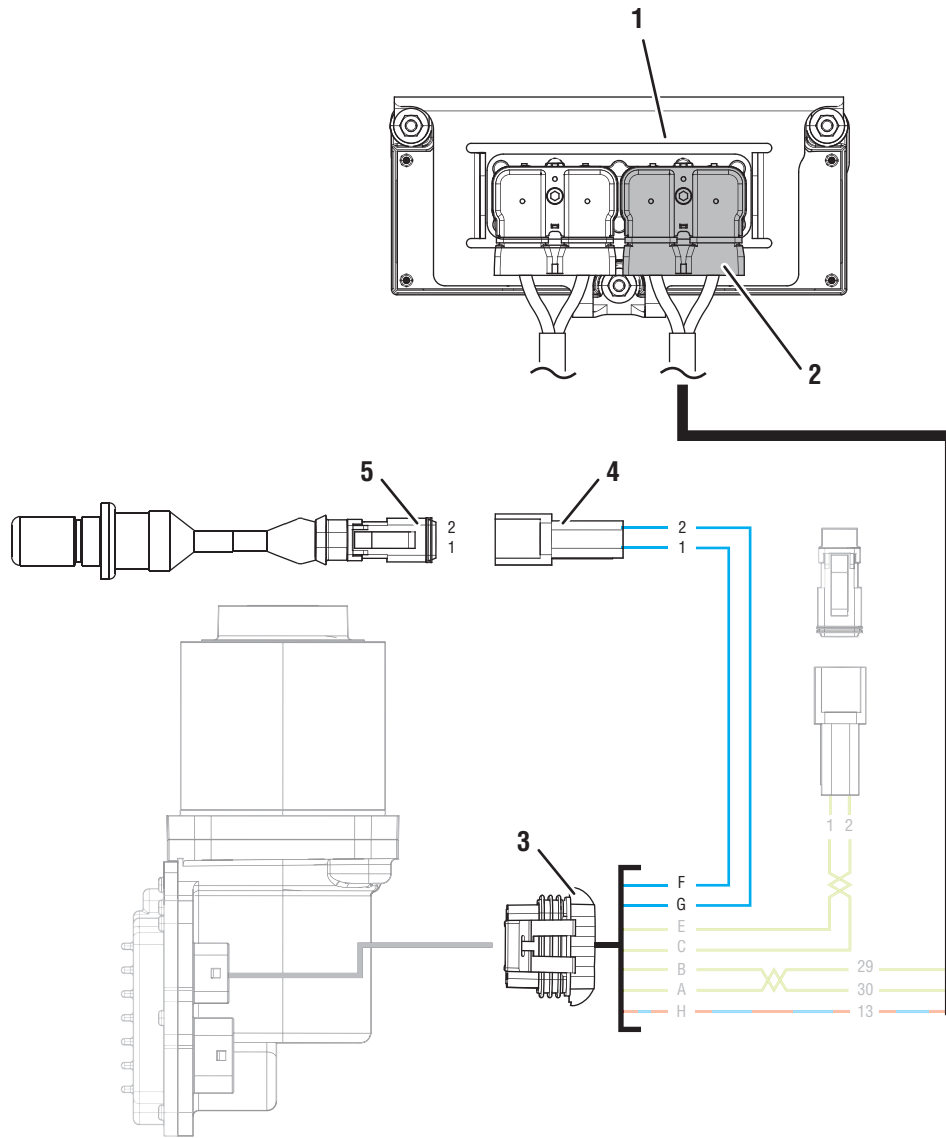

1. Transmission Electronic Control Unit (TECU)
2. 38-Way Transmission Harness Connector
3. 8-Way ECA Connector
4. 2-Way ECA Speed Sensor Connector Body
5. 2-Way ECA Speed Sensor



Fault Code 65 Troubleshooting

A *Purpose: Identify ECA installed on transmission.*

1. Inspect ECA OEM Power Supply Connector, reference image below.

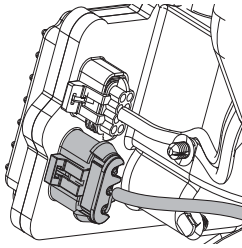

Gen1 ECA

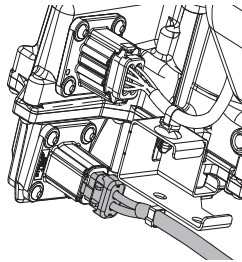

Gen2 ECA

- If equipped with a Gen1 ECA, go to **Step B**.
- If equipped with a Gen2 ECA, refer to the Troubleshooting Guide (TRTS0940, or TRTS0980) on Roadranger.com. Troubleshoot the active code normally and file failed part through normal channels. This pre-authorization DOES NOT apply to Gen2 ECA part.

B *Purpose: Check for Active or Inactive fault codes.*

1. Record the transmission fault codes, FMIs, occurrences, and timestamps from the Service Activity Report created during the Diagnostic Procedure.
 - If Fault Code 56 with FMI 2 is Active, troubleshoot code through normal channels. This Pre Authorization DOES NOT apply to active fc 56 FMI 2.
 - If Fault Code 65 is inactive and there are other active fault codes, troubleshoot active codes, go to troubleshooting Guide (TRTS0940, TRTS0980) on Roadranger.com and troubleshoot active faults. This Warranty Repair Guideline DOES NOT apply when other active codes are present.
 - If Fault Code 65 with FMI 2 or 5 is Active or Inactive, go to **Step C**.

C *Purpose: Check for Active or Inactive fault codes.*

1. Retrieve fault code(s) recorded in Step A.
 - If Fault Code 65 with FMI 2 or 5 is Inactive, go to **Step D**.
 - If Fault Code 65 with FMI 2 or 5 is Active, go to **Step E**.

Pre-Authorized Warranty Repair Guideline RWRG0079

D

Purpose: Use Product Diagnostic (PD) Mode to locate intermittent failures.

1. Set parking brake and chock wheels.
2. Place transmission in PD Mode. See more about Product Diagnostic (PD) Mode on page 6.

Note: Transmission does not enter PD Mode when Active fault codes exist.



3. Wiggle wiring and connections of the Transmission Harness from the 2-Way ECA Speed Sensor to the 8-Way ECA Connector. Look for signs of pinched or chafed wiring. Verify all connections are clean and tight.
4. Exit PD Mode by powering down.



IMPORTANT: Allow 2–3 minutes for the TECU to perform a complete power-down sequence before proceeding.

- If any fault code sets Active while wiggling the Transmission Harness, replace Transmission Harness. Go to **Step V.**
- If any fault code sets Active while wiggling the ECA Speed Sensor wiring, replace ECA Speed Sensor. Go to **Step V.**
- If no fault code sets Active, go to **Step E.**

E

Purpose: Verify resistance of Transmission Harness and ECA Speed Sensor circuit and not shorted to ground.

1. Key off.
2. Disconnect 8-Way ECA Connector.
3. Inspect 8-Way Connector body for damage and bent, spread, corroded or loose terminals.

Note: there are two locations for the ECA Speed Sensor. early models (2010 and older) are typically found at engine flywheel. Late models can be found on clutch housing.

4. Measure resistance between 8-Way Connector Pin F and Pin G. Record reading(s) in table based on configuration.

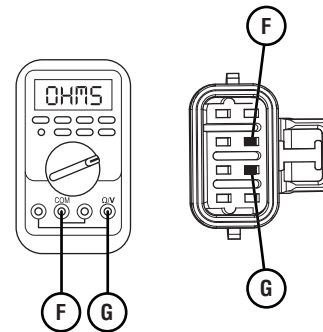

5. Measure resistance between 8-Way ECA Connector Pin F to ground. Record reading(s) in table.

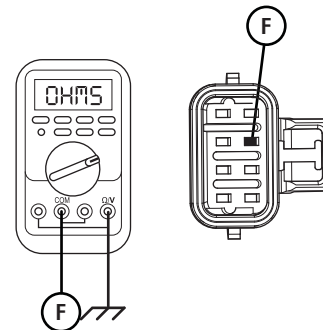

Pre-Authorized Warranty Repair Guideline RWRG0079

6. Compare reading(s) in table.

- If readings are out of range, and harness is undamaged, replace ECA Speed Sensor K-4149 go to **Step V.**
- If readings are in range, replace ECA with updated K-4252. go to **Step V.**

ECA Speed Sensor Location	Pins	Range	Reading(s)
Transmission Clutch Housing	F to G	2.0k–4.5k Ohms	
Engine Flywheel Housing	F to G	140–180 Ohms	
Both	F to ground	Open Circuit (OL)	

V

Purpose: Verify repair.

1. Key off.
2. Reconnect all connectors and verify that all components are properly installed.
3. Key on with engine off.
4. Clear fault codes using ServiceRanger.
5. Drive vehicle and attempt to reset the code or duplicate the previous complaint.
6. Check for fault codes using ServiceRanger.
 - If no fault codes set Active and vehicle operates properly, test complete.
 - If Fault Code 65 sets Active during the test drive, return to transmission specific diagnostic manual for extended trouble shooting.
 - If a fault code other than 65 sets, troubleshoot using appropriate troubleshooting manual.

Pre-Authorized Warranty Repair Guideline RWRG0079

Warranty Parts

- K-4252: Gen 2 ECA, includes adapter harness to OEM power supply and shield.
- K-4149: ECA Speed Sensor
- Varies: Transmission Harness Kit

Warranty Labor

- Transmission Harness R&R – OEM Set
- ECA R&R SRT – 0.7 hrs
- Speed Sensor R&R SRT – OEM Set
- Diagnostics – 0.5 hr
- Check Codes and Send SAR - 0.3 hr
- Software Update if not current version - 0.5 h
- Road test repair confirmation –0.5 hrs

Warranty Coding

- Part: 4306651 (Gen 1 ECA)
or
- Part: 4307350 (ECA Speed Sensor)
- Complaint: FAIL LIGHT FLASHING
- Failure: ROOT CAUSE NOT DETERMINED

Warranty Claim Filing

File Pre-Authorized warranty claim through appropriate OEM or through Direct Pay.

- RWRG0079
- OEM Warranty Coverage
- Software Revision (from and to)

Filing through Direct Pay

Click here for Direct Pay submission guidelines and claim forms:



Warranty Disclaimer

If the failure is not the result of an accident, damage, negligence, abuse or misuse, improper installation or maintenance or any other conditions described in the Limits and Exclusions section of the Eaton Warranty Manual TCWY0600, then Eaton will treat the condition as covered under its warranty. However, this conclusion does not necessarily mean that a defect in fact exists. In all cases, Eaton shall make the final determination and interpretation as to the warrantability of the product.

Parts Disposition

Return Parts per OEM or Direct Pay guidelines.

RWRG0080 - Fault Code 71 Pre-Authorization

Overview

The UltraShift *PLUS* transmission uses the X-Y Shifter to engage and disengage a gear based on the driver's selected mode of operation. Gear disengagement is achieved by activating the X-Y Shifter Gear Motor, which controls the fore-and-aft movement of the Shift Finger. Pushing the Shift Finger against one of the Shift Bar Housing Shift Blocks guides the Shift Yoke to disengage the Sliding Clutch from a gear. The position of the X-Y Shift Finger is monitored by the Transmission Electronic Control Unit (TECU) by way of the X-Y Gear Position Sensor and Rail Position Sensor.

Fault Code 71 is set when the X-Y Shift Finger attempts to pull out of gear, but the X-Y Gear Position Sensor indicates that the transmission was unable to disengage that gear. The TECU detected a system failure, but was unable to detect the specific root cause.

Note: it has been determined that performing an electrical pre-test is not needed.

Symptom(s)

- Transmission may not be able to complete a shift to neutral.
- Engine may not crank.
- Until the fault becomes Inactive, driver may have to shut off engine with transmission in gear.

Warranty Coverage

This Warranty Repair Guideline repair DOES NOT apply if the Fault Code is Inactive and there are other Active Faults in the Eaton/OEM System. If there are other Active Faults, please follow normal troubleshooting procedure using the correct troubleshooting manual per transmission model.

This Pre-Authorization DOES NOT apply if the failed part has been replaced within the last 90 days on the truck.

The warranty coverage varies depending on vehicle vocation and transmission model type. Warranty coverage is the same as that of its respective transmission coverage including extended warranty.

Possible Causes

- Vehicle Power Supply
- Vehicle Batteries
- Transmission Harness
- X-Y Shifter
- Transmission Internal Damage

Component Identification

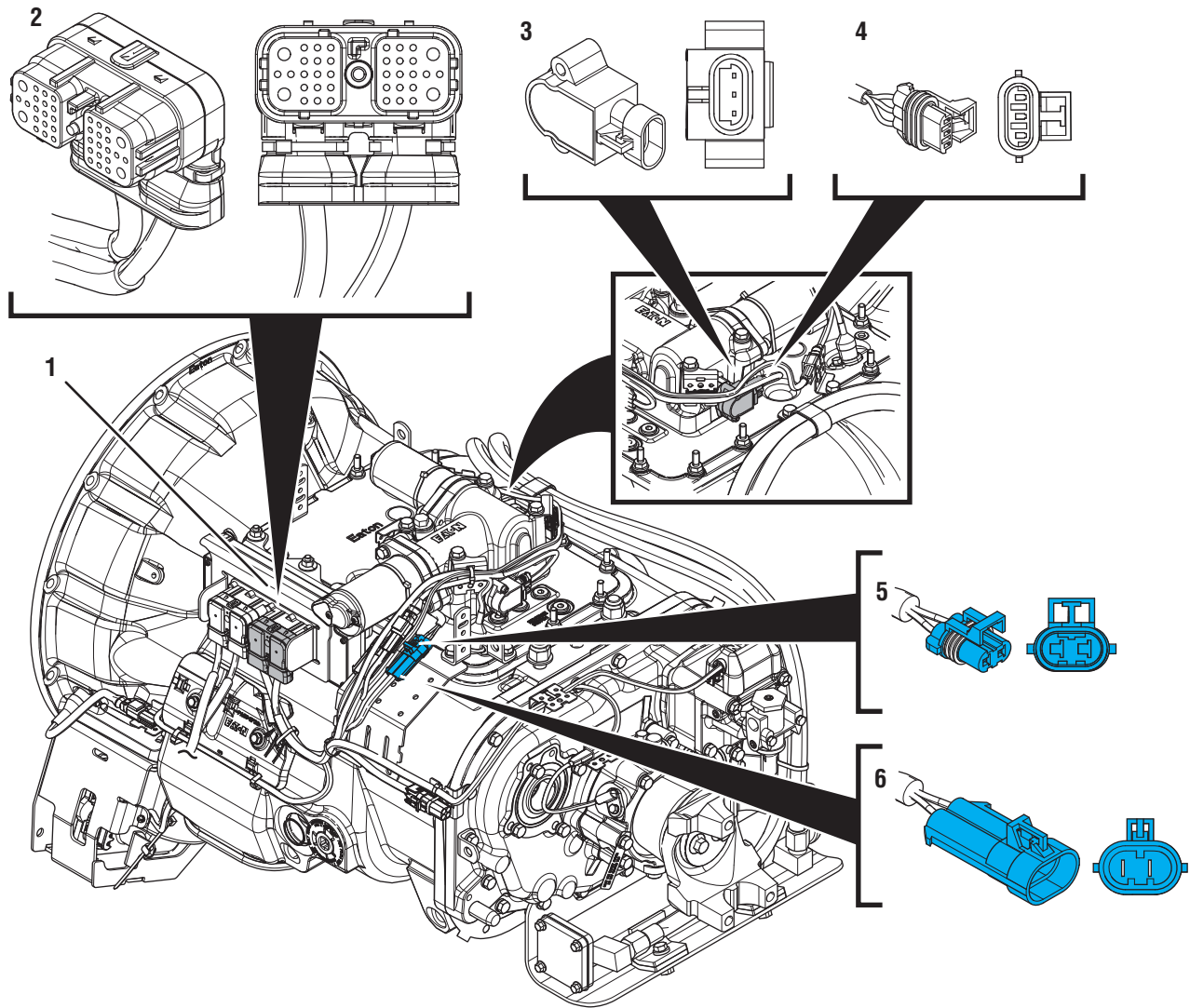

1. Transmission Electronic Control Unit (TECU)
2. 38-Way Transmission Harness Connector
3. Gear Position Sensor
4. 3-Way Gear Position Sensor Connector
5. 2-Way Gear Motor Connector (blue)
6. 2-Way Gear Motor Connector Body (blue)

Pre-Authorized Warranty Repair Guideline RWRG0080

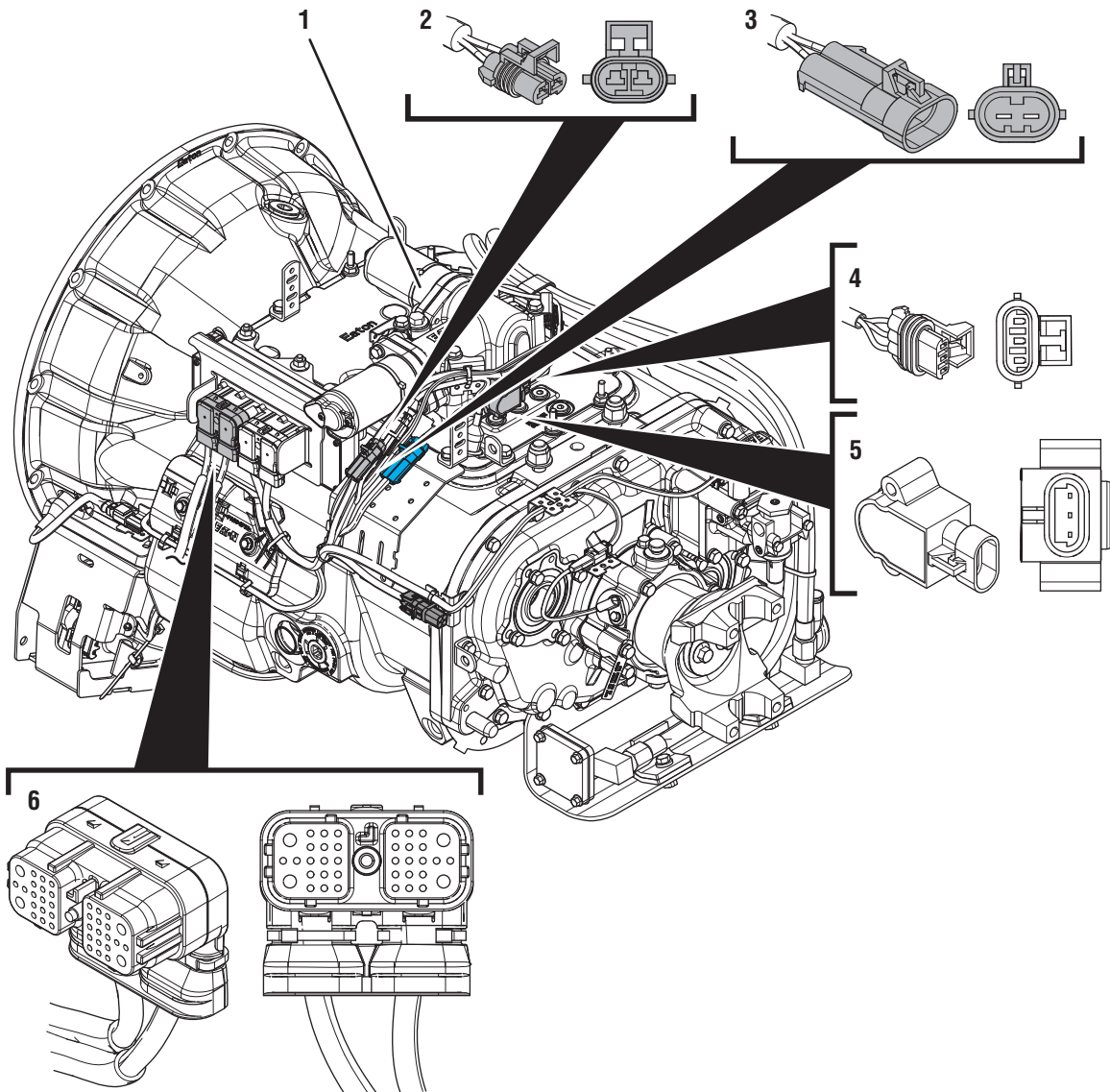

1. X-Y Shifter
2. 2-Way Rail Motor Connector (black)
3. 2-Way Rail Motor Connector Body (black)
4. 3-Way Rail Position Sensor Connector
5. Rail Position Sensor
6. 38-Way Vehicle Harness Connector

Fault Code 71 Troubleshooting

A

Purpose: Check for Active or Inactive fault codes.

1. Record the transmission fault codes, FMIs, occurrences, and timestamps from the Service Activity Report created during the Diagnostic Procedure.
 - If no other Fault Codes are Active, go to **Step B.**

B

Purpose: Inspect condition of X-Y Shifter internal components.

1. Key off.
2. Remove the X-Y Shifter.
3. Inspect condition of the X-Y Shift Finger and Cross Shaft for damage or wear.

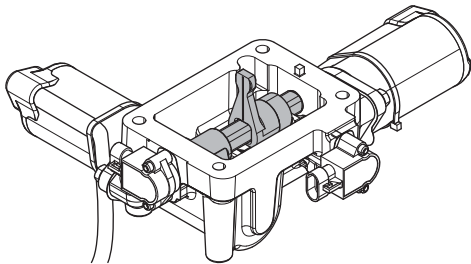

4. Inspect the X-Y Shifter ball screw for signs of coolant contamination.

For the latest Service Bulletin updates, visit Roadranger.com.

- If coolant contamination is found, repair the vehicle coolant system leak and follow Service Bulletin TMIB0124 for complete repair procedure. X-Y Shifter must be replaced upon completion of service bulletin. Repair per RWRG0005 - External Heat Exchange.
- If no contamination is found, replace X-Y Shifter and Transmission Harness. Go to **Step V.**

Pre-Authorized Warranty Repair Guideline RWRG0080

V

Purpose: Verify repair.

1. Key off.
2. Reconnect all connectors and verify that all components are properly installed, including X-Y Shifter.
3. Reinstall 8-bolt PTO cover.
4. Refill transmission with lubricant.
5. Key on with engine off.
6. Clear fault codes using ServiceRanger.
7. Drive vehicle and attempt to reset the code or duplicate the previous complaint.
8. Check for fault codes using ServiceRanger.
 - If no fault codes set Active and vehicle operates properly, test complete.
 - If a fault code other than 71 sets Active, return to transmission specific diagnostic manual for extended trouble shooting.
 - If Fault Code 71 sets Active, troubleshoot using appropriate troubleshooting manual.

Warranty Parts

- K-4223RX
- Transmission Harness Kit

Warranty Labor

- OEM SRT X-Y Shifter R&R
- OEM SRT Transmission harness R&R
- Software Update if not current version - 0.5 h

Warranty Coding

- Complaint: FAIL LIGHT FLASHING
- Failure: ROOT CAUSE NOT DETERMINED

Warranty Claim Filing

File pre-authorized warranty claim through appropriate OEM or through Direct Pay.

- RWRG0080
- OEM Warranty Coverage
- Software Revision (from and to)

Note: Repairs that exceed parts and labor parameters cannot be pre-authorized.

Filing through Direct Pay

Click here for Direct Pay submission guidelines and claim forms:



**Submission Guidelines
and Claim Forms**

Parts Disposition

Return All Parts Per OEM or Direct Pay Guidelines.

Warranty Disclaimer

If the failure is not the result of an accident, damage, negligence, abuse or misuse, improper installation or maintenance or any other conditions described in the Limits and Exclusions section of the Eaton Warranty Manual TCWY0600, then Eaton will treat the condition as covered under its warranty. However, this conclusion does not necessarily mean that a defect in fact exists. In all cases, Eaton shall make the final determination and interpretation as to the warrantability of the product.

RWRG0081 - Fault Code 73 and Various Shift Complaints Pre-Authorization

Overview

This Pre-Authorized Repair is designed to address various shift complaints, outlined below, and may set Fault Code 73.

- Customers may experience intermittent no engagement or delayed engagement from Neutral to a Start Gear (Forward or Reverse). The driver may report that the display indicated a flashing “R”, “1” or “2” during the engagement attempt. The flashing gear display indicates the desired target gear while the transmission is attempting to complete the shift.
- Customers may experience intermittent stuck in gear or failure to shift (indicated gear flashing). The flashing gear display indicates the desired target gear while the transmission is attempting to complete the shift.

Symptom(s)

- Transmission may not be able to complete a shift into gear.
- Sticking in gear/failure to shift.
- Engine may not crank.
- Gear display may flash current or destination gear.
- Gear display is flashing target gear.
- Delayed or no start gear engagement (forward/reverse).

Warranty Coverage

This Warranty Repair Guideline repair DOES NOT apply if the Fault Code is Inactive and there are other Active Faults in the Eaton/OEM System. If there are other Active Faults, please follow normal troubleshooting procedure using the correct troubleshooting manual per transmission model.

This Pre-Authorization DOES NOT apply if the failed part has been replaced within the last 90 days on the truck. The warranty coverage varies depending on vehicle vocation and transmission model type. Warranty coverage is the same as that of its respective transmission coverage including extended warranty.

Possible Causes

- Vehicle Power Supply
- Vehicle Batteries
- Transmission Software
- Transmission Engine Calibration
- Transmission Harness/X-Y Shifter
- Internal Transmission Damage

Component Identification

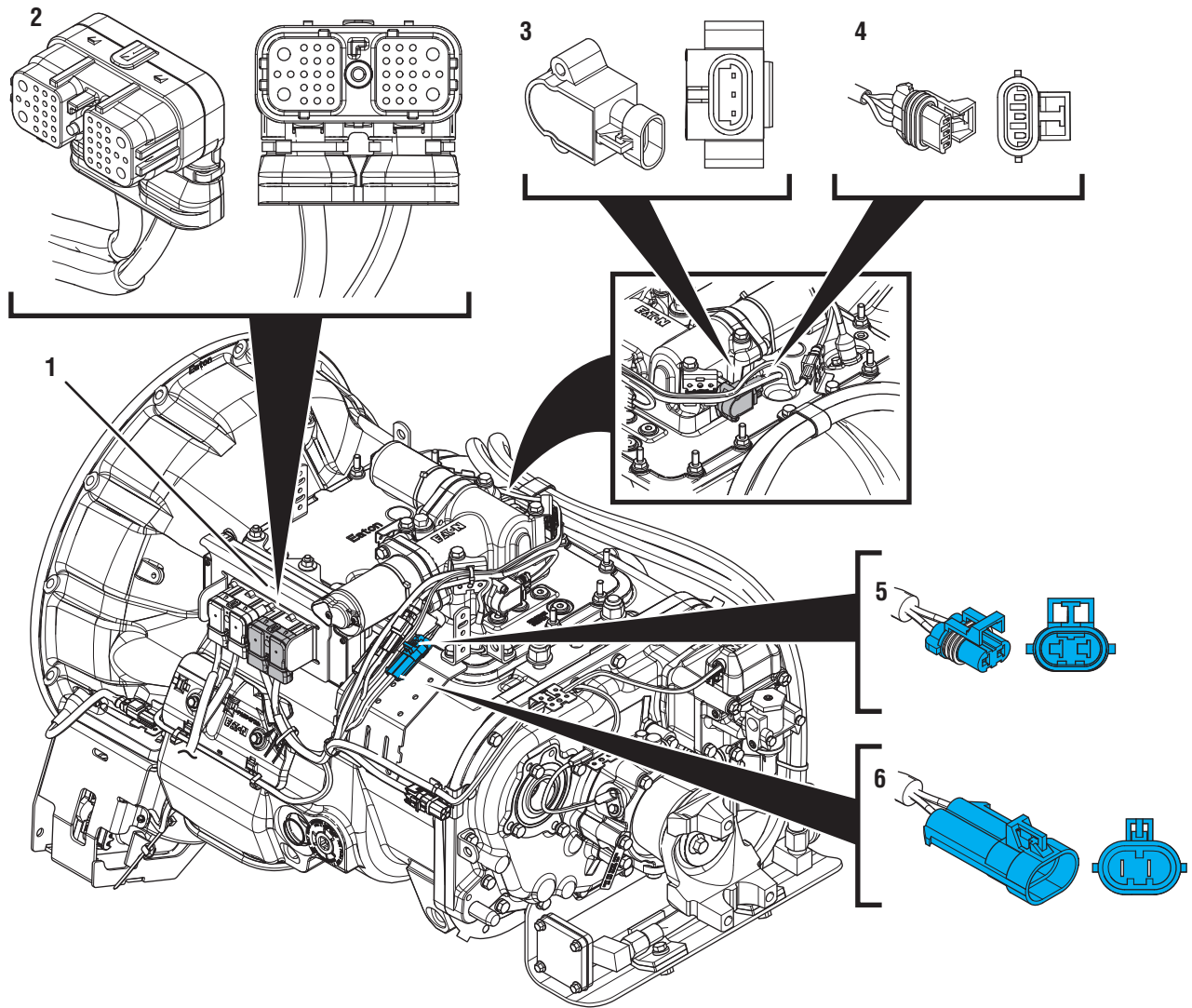

1. Transmission Electronic Control Unit (TECU)
2. 38-Way Transmission Harness Connector
3. Gear Position Sensor
4. 3-Way Gear Position Sensor Connector
5. 2-Way Gear Motor Connector (blue)
6. 2-Way Gear Motor Connector Body (blue)

Pre-Authorized Warranty Repair Guideline RWRG0081

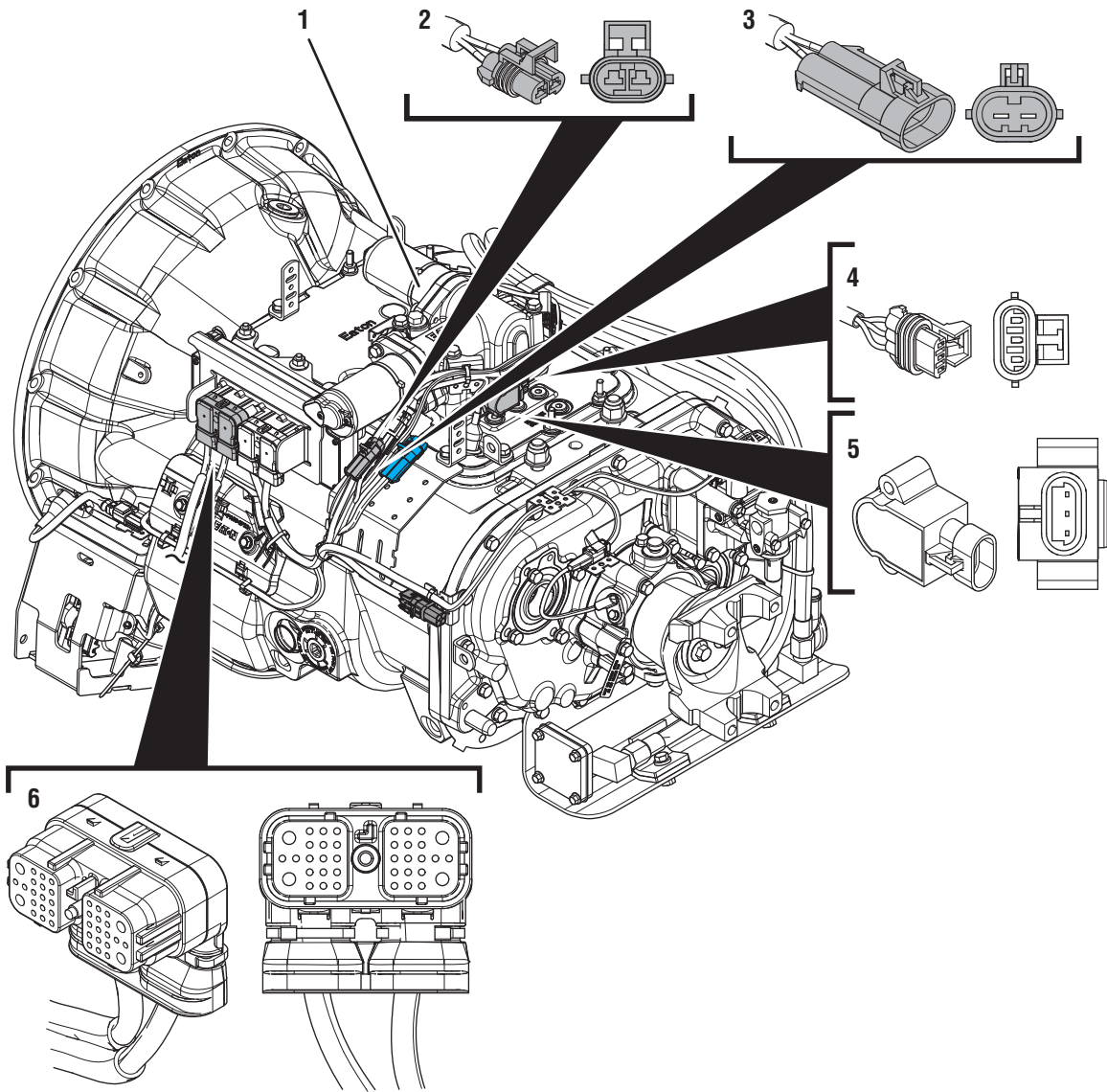

1. X-Y Shifter
2. 2-Way Rail Motor Connector (black)
3. 2-Way Rail Motor Connector Body (black)
4. 3-Way Rail Position Sensor Connector
5. Rail Position Sensor
6. 38-Way Vehicle Harness Connector

Fault Code 73 Troubleshooting

A *Purpose: Check Fault Codes and Verify Transmission Model.*

1. Key on.
2. Connect ServiceRanger.
3. Record the transmission fault codes, FMIs, occurrences, and timestamps from the Service Activity Report created during the Diagnostic Procedure. Inspect transmission for model number.
 - If Fault Code 73 is Inactive and there are Active fault codes present, this Pre-Authorization does not apply. Refer to the Fault Code Isolation Procedure Index in the appropriate troubleshooting guide.
 - If the transmission is a Fuller Advantage model, FA/FAO(M), go to **Step B.**
 - If the transmission is an UltraShift *PLUS* model, go to **Step D.**

B *Purpose: Verify TECU Software Version.*

1. Key on.
2. Connect ServiceRanger.
3. Go To Programming.
4. Record Software Information - TECU.
 - If software version is less than 5569976, update to software to latest available software. Go to **Step C.**
 - If software version is 5569976 or greater, go to **Step C.**
 - If software version 5569976 is not indicated, verify ServiceRanger is up to date or contact Eaton at 1-800-826-HELP (4357) for further diagnostic instructions.

C *Purpose: Verify Engine Calibration Configuration Setting.*

1. Go To Configuration.
2. Select Engine.
3. Record Engine Calibration Current Value.
 - If the Current Value indicates “Enhanced Gear Engagement 5573528”, go to **Step D.**
 - If the transmission model is anything other than EC3, EP3, EN3, EA3, go to **Step D.**
 - If the Current Value does not indicate “Enhanced Gear Engagement 5573528”, select the New Value drop down arrow, select “Enhanced Gear Engagement 5573528” and follow on-screen prompts. Go to **Step V.**

Pre-Authorized Warranty Repair Guideline RWRG0081

D

Purpose: Replace XY Shifter and Harness.

1. Key off.
2. Remove the X-Y Shifter
3. Inspect the X-Y Shifter for damage and coolant contamination (UltraShift *PLUS* models).
 - If no damage or contamination is evident, replace X-Y Shifter and Transmission Harness. Go to **Step V.**
 - If cooler contamination is present, repair coolant leak and follow TMIB0124 for complete repair instructions. Submit the repair using Pre-Authorized Repair RWRG0005 - External Heat Exchanger.

Note: To access the latest Service Bulletin information, go to www.roadranger.com.

V

Purpose: Verify repair.

1. Key off.
 2. Reconnect all connectors and verify that all components are properly installed.
 3. Key on.
 4. Clear fault codes using ServiceRanger.
 5. Drive vehicle (0.5 hour) and attempt to reset the code or duplicate the previous complaint.
 6. Check for fault codes using ServiceRanger.
 - If no codes set and the vehicle operates properly, Test Complete.
 - If Fault Code 73 sets Active during the test drive or the previous complaint is duplicated, contact Eaton at 1-800-826-HELP (4357) for further diagnostic instructions.
 - If a fault code other than 73 sets, refer to the Fault Code Isolation Procedure Index in the appropriate troubleshooting guide.
-

Pre-Authorized Warranty Repair Guideline RWRG0081

Warranty Parts

- X-Y Shifter: K-4223RX
- Transmission Harness: Varies

Warranty Labor

- XY Shifter SRT
- Transmission Harness SRT
- Software Update: 0.5 HR
- Road Test: 0.5 HR
- Diagnostics: 0.5 HR

Warranty Coding

Note: Internal use only

- Complaint: Shifting - Missed
- Failure: FC 73-7 - Downshift Into 7th

Warranty Claim Filing

File pre-authorized warranty claim through appropriate OEM or through Direct Pay.

- RWRG0081
- OEM Warranty Coverage
- Software Revision (from and to)

Note: Repairs that exceed parts and labor parameters cannot be pre-authorized.

Filing through Direct Pay

Click here for Direct Pay submission guidelines and claim forms:



Parts Disposition

Return All Parts Per OEM or Direct Pay Guidelines.

Warranty Disclaimer

If the failure is not the result of an accident, damage, negligence, abuse or misuse, improper installation or maintenance or any other conditions described in the Limits and Exclusions section of the Eaton Warranty Manual TCWY0600, then Eaton will treat the condition as covered under its warranty. However, this conclusion does not necessarily mean that a defect in fact exists. In all cases, Eaton shall make the final determination and interpretation as to the warrantability of the product.

Roadranger Warranty Repair Guideline RWRG0067

RWRG0067 - Shift Complaints, No Transmission Fault Codes

Symptom(s)

- Does not make upshifts in auto mode without backing out of the throttle, but will upshift manually. Engine may also be unresponsive to throttle input.
- Gear display shows current gear, solid, no upshift or downshift arrows, no flashing “F”.
- Typically no transmission fault codes reported.

Cause

1. Engine issues (fault codes, fuel system, boost) de-rating the engine power.
2. Engine software changes overwriting Automated transmission settings.
3. Known Engine Software compatibility issues.
4. Changes in transmission and/or engine programmable parameters such as governed RPM and road speed limits.
5. Engine accessories (cooling fan, AC, PTO) not operating properly.
6. Data link availability/message priority issues.
7. Other modules setting data link faults or overloading the link with messages.
8. Intermittent data link failures.
9. Unintended ABS/ traction control events.

Background Information

- Automated Transmissions rely on engine torque, speed and throttle data to calculate shift strategies. When engine conditions occur that cause low torque output, (engine faults, high coolant temp), this causes the transmission shift calculations to change. Similarly, accessory loads that are not operating correctly (fan is on when commanded off) are not figured into reported 'net' torque correctly, causing biased shift calculations. These conditions cause shift complaints but are not caused by the transmission.
- Automated transmissions rely on data link integrity to communicate shift commands to the engine. If the data link hardware degrades, intermittently fails, is overloaded with messages from other modules (ABS, VORAD, etc), this causes a shift complaint. Safety events like traction control/ABS override transmission shift commands and may cause a shift complaint. These conditions cause shift complaints but are not caused by the transmission.

Repair Guideline

Investigate and repair engine performance issues. Repair any engine fault codes, emissions, boost, coolant temp, fuel and intake air system issues.

Investigate and resolve engine software issues. Resolve any customer-programmable parameters, engine parameter settings (reference Eaton Engine Configuration Guide TAIB0910), software updates and software compatibility issues.

Investigate and repair engine accessory loads. Resolve engine cooling fan, A/C, PTO and other accessory performance issues. Note- Cooling fans normally default engaged during a fan control failure to protect the engine from overheating. A cooling fan constantly running often indicates a failure.

Investigate and repair data link issues. Resolve issues with data link hardware (including module grounds) and other modules interfering with data link operation.

Resolve any unintended ABS/ Traction Control events as these override transmission shift commands.

Warranty Parts

None

Warranty Labor

None

Warranty Coding

Part: NONEATON

Complaint: Varies by failure

Failure: Varies by failure

Responsibility Code: REJECTED CLAIM

Parts Disposition

Refer to OEM guidelines for parts disposition.

Warranty Disclaimer

If the failure is not the result of accident, damage, negligence, abuse or misuse, improper installation or maintenance or any other conditions described in the Limits and Exclusions section of Warranty Manual TCWY0600, then Roadranger will treat the condition as covered under its warranty. However, this conclusion does not necessarily mean that a defect in fact exists. In all cases, Roadranger shall make the final determination and interpretation as to the warrantability of the Product.

Warranty will not pay damage caused from a low lube condition or consequential damage caused by the leak left unrepaired.

Copyright Eaton, 2017

Eaton hereby grant their customers, vendors, or distributors permission to freely copy, reproduce and/or distribute this document in printed format. It may be copied only in its entirety without any changes or modifications. THIS INFORMATION IS NOT INTENDED FOR SALE OR RESALE, AND THIS NOTICE MUST REMAIN ON ALL COPIES.

Note: Features and specifications listed in this document are subject to change without notice and represent the maximum capabilities of the software and products with all options installed. Although every attempt has been made to ensure the accuracy of information contained within, Eaton makes no representation about the completeness, correctness or accuracy and assumes no responsibility for any errors or omissions. Features and functionality may vary depending on selected options.

For spec'ing or service assistance, call 1-800-826-HELP (4357) or visit www.eaton.com/roadranger. In Mexico, call 001-800-826-4357.

Roadranger: Eaton and trusted partners providing the best products and services in the industry, ensuring more time on the road.

Eaton

Vehicle Group
P.O. Box 4013
Kalamazoo, MI 49003 USA
800-826-HELP (4357)
www.eaton.com/roadranger

Printed in USA

Roadranger

